

# Complete and reliable solar fusible circuit protection



*Powering Business Worldwide*



Eaton has more than 100 years of proven technical innovation to help make your operation more productive while protecting your equipment.

Solar Photovoltaic (PV) systems have evolved into a mature, sustainable and adaptive technology. The growth in installations and demand for PV systems necessitate effective electrical protection. PV systems, as with all electrical power systems, must have appropriate overcurrent and overvoltage protection.

Eaton has worked closely with solar system manufacturers, and through coordinated research and development, has produced revolutionary photovoltaic fuse links which work in combination with solar array combiner systems to offer a complete protection for PV applications.

# Table of contents

Section	Page
Eaton's Bussmann series solar technology solution	4 - 5
Introduction	6
IEC 60269-6 gPV standard	6
Photovoltaic module	
Construction	7
Output	7
String protection	
Overview	8
How to select fuse links for string protection	9
Worked example	10
Array Protection	
Overview	11
How to select fuse links for array protection	12
Worked example	13
Solar fuse links overview	14
10 x 38 mm PVM fuse links	15
10 x 38 mm PV-A10 fuse links	17
CHPV Modular fuse holders	22
10 x 85 mm PV-A10F85L fuse links	23
CHPV15L85 fuse holder	25
14 x 51 PV-A14F fuse links	26
CHPV14 Modular fuse holders	28
FW14-PCB Mountable fuse clips	29
14 x 65 mm PV-A14L fuse links	30
NH style PV-ANH fuse links	34
NH Bases SD-D-PV	43
Flush end PV-AF fuse links	45
XL style PVXL fuse links	48
SD-S-PV XL Bases	62
NH Style 800 V a.c. 170M fuse links	63
170H Microswitches	68
Index	70

# Eaton's Bussmann series solar technology solution

**PVM, 10 x 38, 10 x 85, 14 x 51, 14 x 65 mm photovoltaic fuse links. Rated voltage: from 600 V d.c. to 1500 V d.c.**



**1**

**CHPV fuse holder. Rated voltage: up to 1500 V d.c.**



**1**

**BM series fuse block**



**1**

**PV Flush end fuse links. Rated voltage: 1000 V d.c.**



**2**

**3**

**NH Style photovoltaic fuse links and fuse holders. Rated voltage: 1000 V d.c.**



**2**

**XL Style photovoltaic fuse links and fuse bases. Rated voltage: 1000 and 1500 V d.c.**



**2**

**Square body, BS and UL High speed fuse links. Rated voltage: Up to 4000 V d.c.**

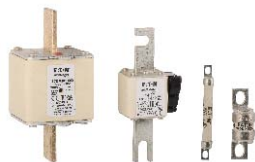

**3**

**NH Low voltage fuse links and fuse holders. Rated voltage: 400, 500 and 690 V a.c.**



**4**

## String protection

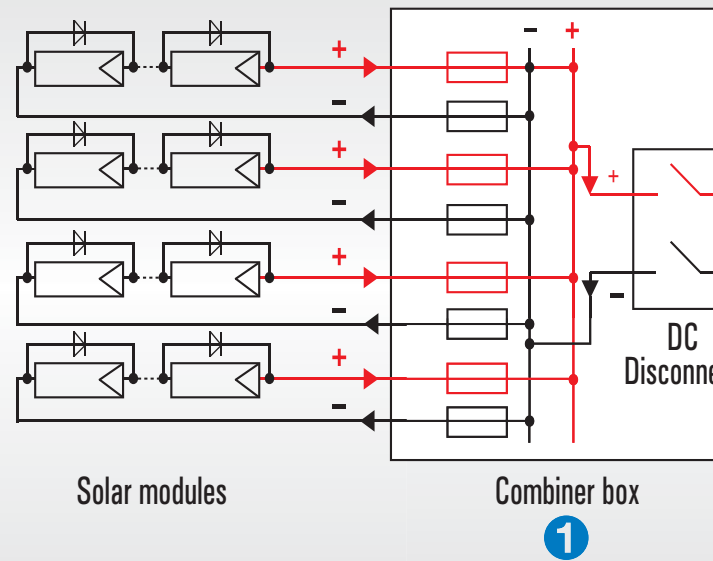
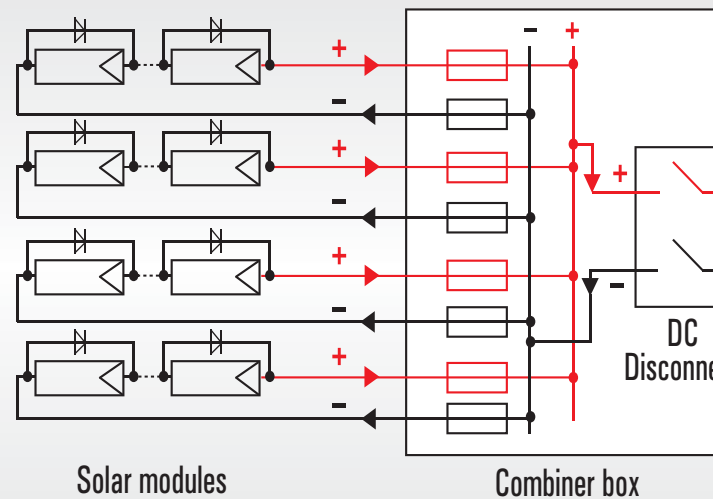

## Array protection

## Inverter protection

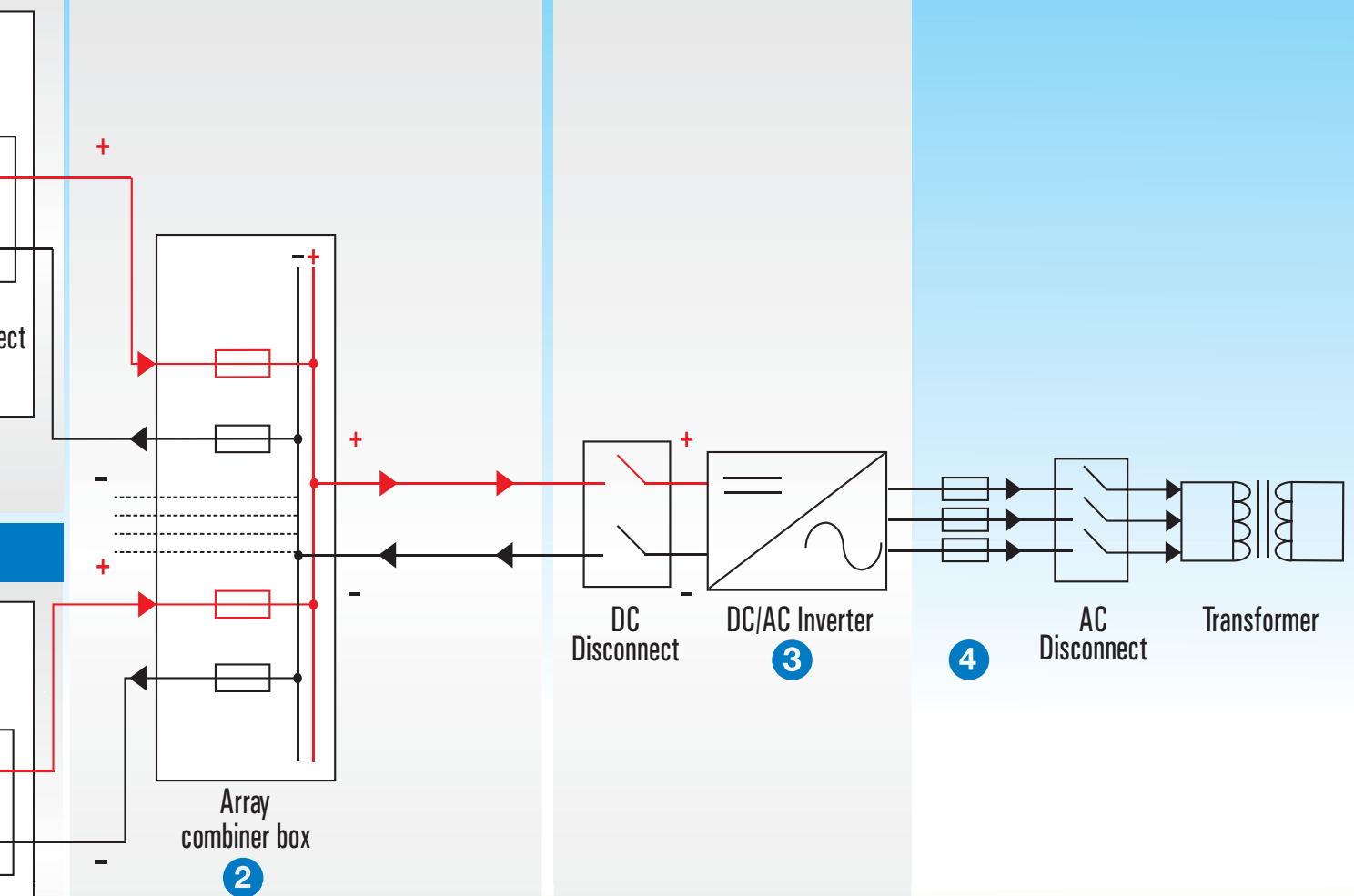

# Introduction

The global transition from fossil fuels to renewable sources is well under way. Photovoltaic (PV) have proven to offer an environmentally sustainable solution to our ever increasing energy demands while also being cost competitive. This has led to the increase of installed capacity of PV systems from 574 GW in 2019 growing to 1064 GW expected by 2023. This rapid growth size and output capacity of these installations has challenged system designers, manufacturers and standards organisations due to the specific demands associated with PV installation in terms of current, voltage, and ambient temperature. These requirements have also been considered in the development of international protection standards for PV installations, which Eaton, the leading name in electrical protection, has used to develop PV specific protection devices.

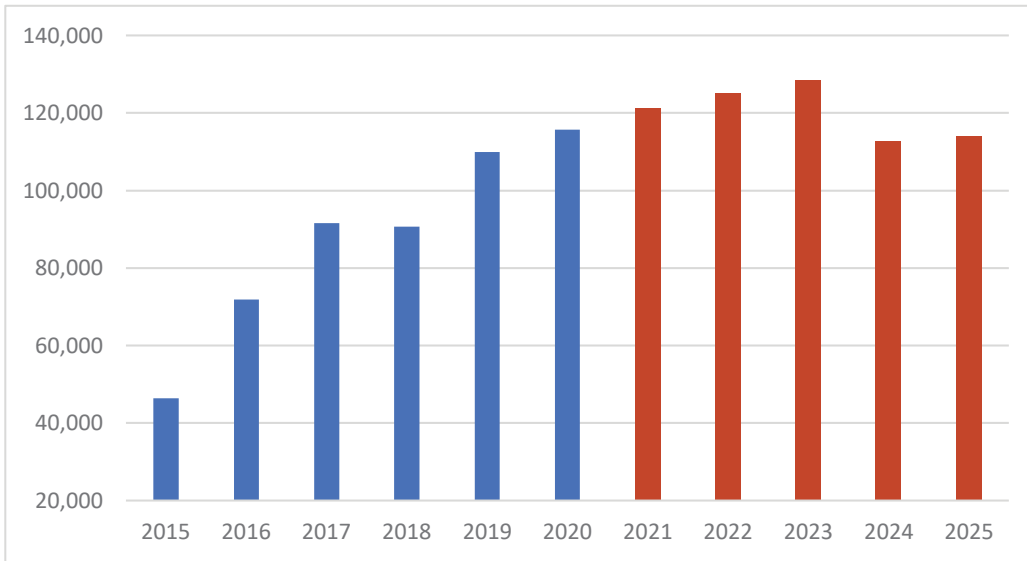

Global annual photovoltaic installations (Megawatt). Source: EPIA

## IEC 60269-6 gPV standard

**Unlike typical grid connected AC systems, the available short-circuit current within PV systems is limited and the overcurrent protective devices need to operate effectively on low levels of fault current. For this reason Eaton has conducted extensive research and development of fuse links that are specifically designed and tested to safely protect PV systems with high DC voltages and low fault currents.**

The International Electrotechnical Commissions (IEC) recognise the protection of PV systems is different to standard electrical installations. This is reflected in IEC 60269-6 which defines specific characteristics that a fuse link is required to meet for protecting PV systems, utilisation class gPV. Eaton's Bussmann series string and branch PV fuse links have been specifically designed to meet this standard. However, Eaton's Bussmann series PV fuse links exceed the requirements of IEC 60269-6 as they operate at  $1.35 \times I_n$  (1.35 times the nominal current). They also meet the requirements of UL 2579 and are thus suitable for protecting PV modules in reverse current situations.

Whilst the standard does not recognise a specific symbol, the combination of the symbols for fuse link and strings are often used to indicate a fuse link is suitable for protecting strings in PV systems, see Figure 1.



Figure 1

# Photovoltaic module construction

- A photovoltaic (PV) cell is usually between 4" and 6" square.
- A number of individual cells are combined in a module (often called a panel).
- A number of PV modules in series is referred to as a string.
- A number of strings in parallel is referred to as an array.

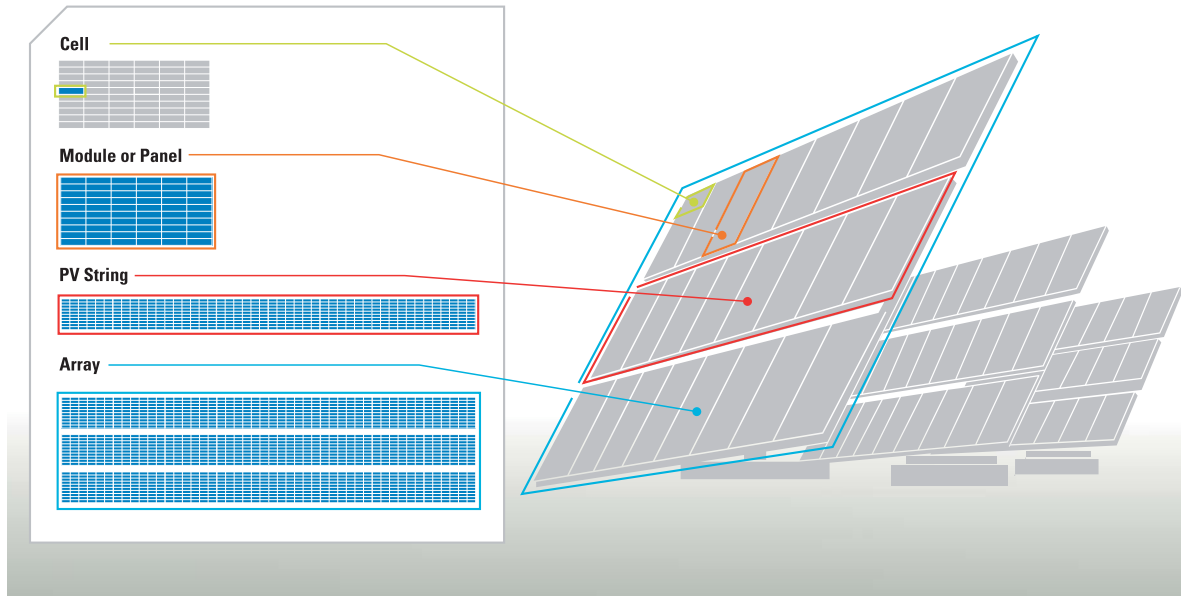

Figure 2

## Photovoltaic module output

**The voltage output of a PV module is defined by the number of cells in series that form the module.**

**The current output of a PV module is dependent on the area of a cell.**

**The most widely used solar modules are made with 4", 5" and 6" poly-crystalline silicon cells. This type of module using 6" cells, can achieve approximately 8 Amps maximum power point (MPP) current per module with a typical voltage output of around 30 Volts.**

**With thin film technology typical output is 2.5 Amps and 40 Volts.**

The maximum power point current of the modules vary between manufacturers of equal solar cell dimensions. When selecting the appropriate fuse links, the specified Short Circuit Current ( $I_{SC}$ ) and reverse current characteristics specified by the manufacturers should be used.

The specifications provided by the module manufacturer should be consulted to confirm the output currents and voltages of the modules under the range of conditions expected for the proposed installation. These conditions are influenced by the ambient temperature, the incident angle of sunlight and the amount of solar energy reaching the module. These are usually mentioned as coefficients on the manufacturer's specifications.

Manufacturers also suggest the maximum series fuse rating or a reverse current rating. Both of these are based on modules surviving 1.35 times this rating for two hours.

# Overview of string protection

Depending on the desired capacity of the Photovoltaic (PV) system, there may be several PV strings connected in parallel to achieve higher currents and subsequently more power.

PV systems that have three or more strings connected in parallel need to have each string protected. Systems that have less than three strings will not generate enough current to damage the modules in the event of a fault. Therefore they do not present a safety hazard, provided the conductor is sized correctly, based on local codes and installations requirements.

Where three or more strings are connected in parallel, a fuse link in each string will protect the cables and modules from overcurrent faults and help minimise any safety hazards. It will also isolate the faulted string so that the rest of the PV system can continue to generate electricity.

It should be remembered that PV modules current output changes with the module temperature as well as the amount of sun they are exposed to. The exposure is dependant on irradiance level, incline as well as shading effect from trees, buildings or clouds. In operation, fuse links, as thermal devices, are influenced by ambient temperature. The current capability of Eaton's Bussmann series PV string fuse links should be derated according to the curves below.

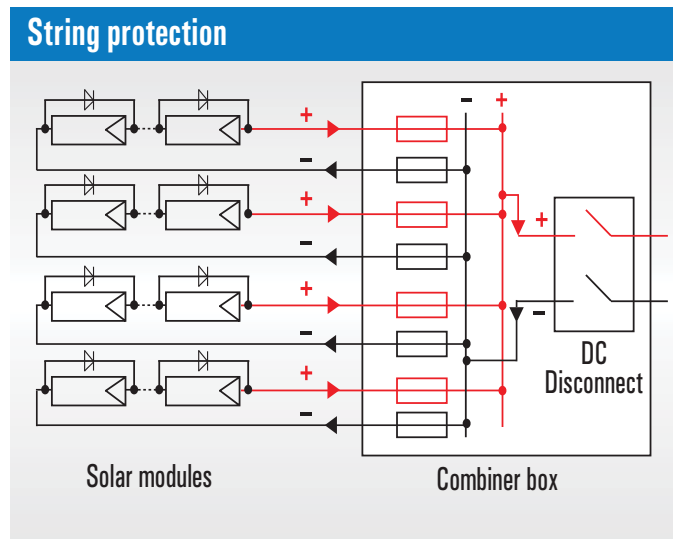
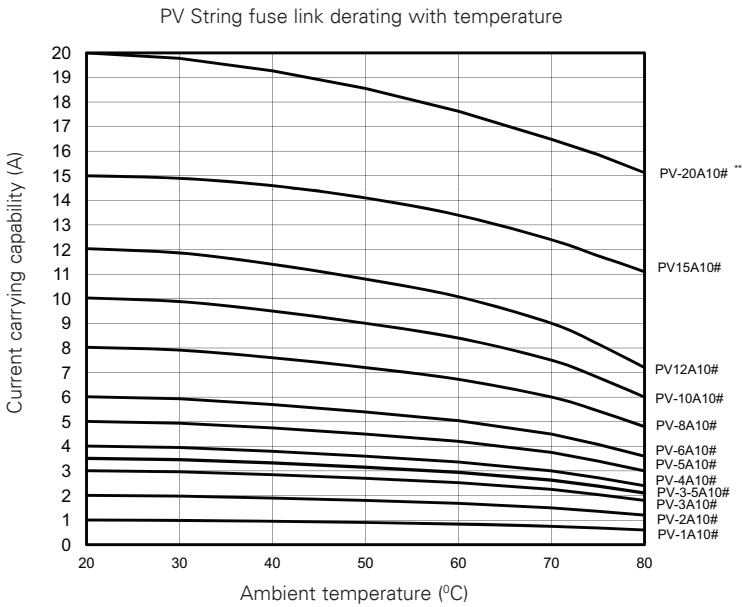

# How to select fuse links for string protection

Whilst a full study of all the parameters is recommended, the following factors should be used: 1.56 for current and 1.2 for voltage when selecting the fuse link. These cover most variations due to installation. The same method should be adopted for crystalline and thin film modules.

If your PV installation is subject to extremes of high altitude, high irradiance, or low temperature, please consult Eaton's Field Application Engineers: [bulehighspeedtechnical@eaton.com](mailto:bulehighspeedtechnical@eaton.com).

## Define the specifications of the PV module

### Criteria

$I_{sc}$ : Short-circuit current of the module at Standard Test Conditions (STC) - Data provided by the PV Manufacturer

$V_{oc}$ : Open circuit voltage of one module at STC - Data provided by the PV Manufacturer

$N_s$ : Number of modules in series per string

$N_p$ : Number of strings in parallel per array

$I_{mod\_max\_OCPR}$ : The PV module maximum overcurrent protection rating specified by IEC 61730-2 (this is often specified by module manufacturers as the maximum series fuse rating)

### If $N_p \leq 3$ and the cable is rated at $1.56 \times I_{sc}$

For PV installations with three or less parallel strings and string cables adequately sized, fusing might be needed if local installation regulations or codes require them.

However Eaton recommends fuse links protection in all PV systems as unpredicted fault currents may occur in the event of inverter failure where batteries are connected to the strings.

### If $N_p > 3$

The fuse link's rating should be selected as follows:

- Voltage rating  $\geq 1.20 \times V_{oc} \times N_s$
- Current rating  $\geq 1.56 \times I_{sc}$
- Check the current carrying capability of the selected fuse after derating at the ambient temperature of the fuse still satisfies the above criteria
- Current rating  $\leq I_{mod\_max\_OCPR}$
- Current rating  $\leq I_z$  = string cable rating
- Altitude derating

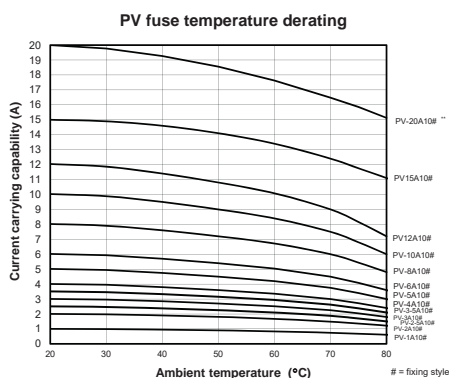

For PV application with fuse links installed at high altitudes, there is reduced cooling effect on the fuse as the density of the atmosphere reduces. For above 2000 metre sea level, every 100 metre increase will have 0.5% de-rate on the fuse current. Please consult Eaton's Fuse Application Engineers for further information: [bulehighspeedtechnical@eaton.com](mailto:bulehighspeedtechnical@eaton.com)

### Cable protection

Fuse links are required to protect cables and PV modules to prevent fires and ensure the fuse could open a fault circuit safely during an overcurrent fault.

For  $N_p \leq 3$ , a fuse might not be required as stated above, but cable should be rated at  $1.56 \times I_{sc}$  or higher.

For  $N_p > 3$ , a fuse is needed to protect both the PV modules and the cables. The cable should be rated big enough to carry the load current. If cable rating is too small, there is a risk of nuisance tripping. Also it is important to ensure the fuse link current rating < string cable rating for fuse to protect the cables.

# String protection — worked example

Once it has been determined that the maximum short-circuit current exceeds the cable's continuous current rating, the recommendations for selecting the correct PV string fuse link are as follows:

## Manufacturer's PV Module specifications

### PV Module description

- Maximum system voltage: 1000 V d.c.

### Electrical data

- Open circuit voltage ( $V_{oc}$ ): 43.1 V
- Short-circuit current ( $I_{sc}$ ): 5.37 A
- Maximum series fuse rating: ( $I_{mod\_max\_OCPR}$ ): 15 A

## PV Installation set-up

- 18 modules in series per string ( $N_s = 18$ )
- Maximum 60°C module
- Minimum -30°C module
- Maximum 45°C ambient fuse link
- 4 strings in parallel ( $N_p = 4$ )
- Cable size:  $2.5 \text{ mm}^2 \geq$  cable rating  $I_z = 11.5 \text{ A}$  at 60°C (manufacturer's data)

## Calculation

- Cable rating  $\geq 1.56 \times I_{sc} = 1.56 \times 5.37 = 8.38 \text{ A}$ . Selected cable  $I_z = 11.5 \text{ A} \rightarrow$  The selected cable is suitable

$$\begin{aligned} \text{String max short-circuit current } I_{sc\_string} &= (N_p - 1) \times 1.25^* \times I_{sc} \\ &= (4 - 1) \times 1.25^* \times 5.37 \\ &= 20.1 \text{ A} \end{aligned}$$

$I_{sc\_string}$  (20.1 A  $>$   $I_z$  (11.5 A), therefore string fuse links are needed.

\* NEC states the maximum circuit current for PV circuit is defined as 1.25 multiplied by PV model rated short-circuit current  $I_{sc}$  or the sum of parallel PV module rated short-circuit.

- Minimum fuse current rating  $I_n \geq 1.56 \times I_{sc}$   
 $= 1.56 \times 5.37 = 8.38 \text{ A}$

- Maximum fuse current rating  $I_n \leq I_{mod\_max\_OCPR} = 15 \text{ A}$   
 $I_n \leq I_z \text{ cable rating} = 11.5 \text{ A}$

- Minimum fuse voltage rating  $U_n \geq 1.2 \times V_{oc} \times N_s$   
 $= 1.2 \times 43.1 \times 18 = 931 \text{ V}$

The selected fuse link needs to be rated at 10 A and 1000 V d.c.

Eaton's Bussmann series catalogue is PV-10A10F

The selected fuse link has current carrying capability of 9.3 A at 45°C ambient temperature, which is greater than the minimum fuse current rating (8.38 A). Therefore the fuse link selected will protect the cables and the modules against reverse current faults.

# Overview of array protection

Depending on the desired capacity of the Photovoltaic (PV) system, there may be several PV strings connected in parallel to achieve higher currents and subsequently more power.

A fuse link on each array will protect the cables from fault current and help minimise any safety hazards. It will also isolate the faulted array so that the rest of the PV system can continue to generate electricity.

A fuse link positioned in the cable that carries the combined output of a number of strings should be protected by array fuse links. If a number of arrays are subsequently combined then a further fuse link should be incorporated.

It should be remembered that the characteristics of PV modules vary with module temperature as well as irradiance level. In operation fuse links are influenced by ambient temperature.

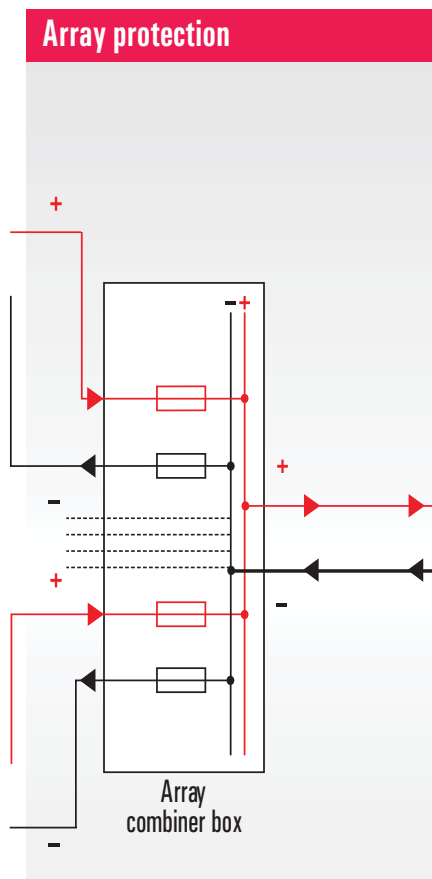
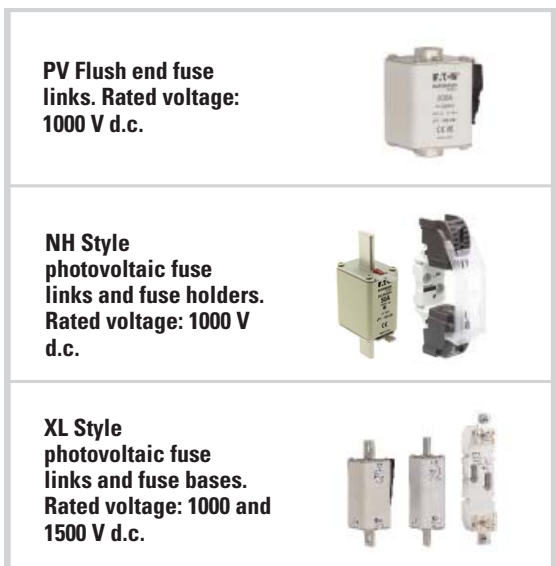
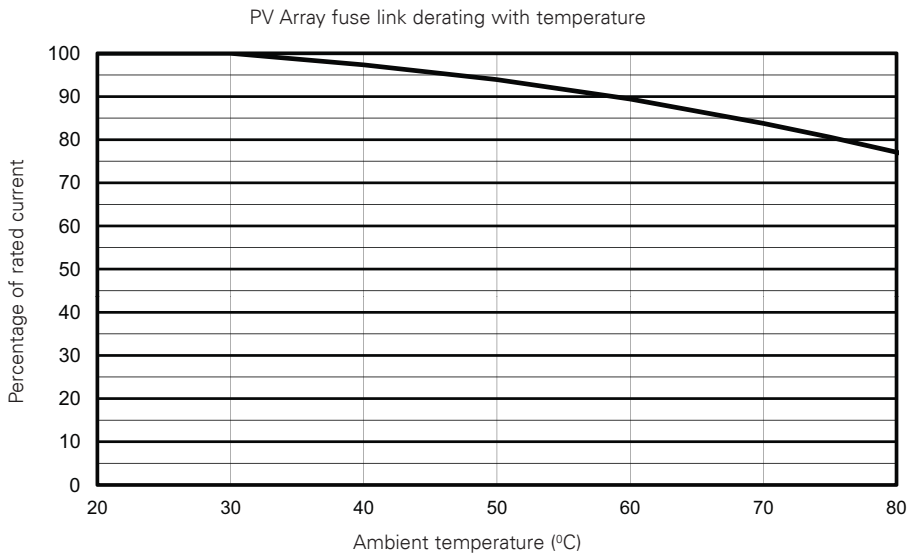

# How to select fuse links for array protection

Whilst a full study of all the parameters is recommended, in general the following factors should be used: 1.56 for current and 1.2 for voltage when selecting the fuse link. These cover most variations due to installation. If you have concerns that your PV installation may be subject to extremes of high altitude, high irradiance, high or low temperature, please consult Eaton's technical team (bulehighspeedtechnical@eaton.com).

## Define the specifications of the PV module

### Criteria

$I_{sc}$ : Short-circuit current of the module at Standard Test Conditions (STC) - Data provided by the PV Manufacturer

$V_{oc}$ : Open circuit voltage of one module at STC - Data provided by the PV Manufacturer

$N_s$ : Number of modules in series per string

$N_p$ : Number of strings in parallel per array

$N_A$ : Number of arrays in parallel

According to IEC 62548, 6.5.5.2 PV sub-array overcurrent protection. The nominal rated current ( $I_n$ ) of overcurrent protection devices for PV sub-arrays shall be determined with following formula:

$$I_n > 1.25 \times I_{sc\_Array} \text{ and } I_n \leq 2.4 \times I_{sc\_Array}$$

In accordance with the National Electrical Code (NEC) fuses are selected using  $1.56 \times I_{sc}$ . As fuse manufacturer, Eaton's recommends the array fuse selection method below in order to satisfy both IEC and NEC requirements.

The fuse link's ratings should be selected as follows:

- Voltage rating  $\geq 1.20 \times V_{oc} \times N_s$
- Current rating  $\geq 1.56 \times I_{sc} \times N_p$
- Check the current carrying capability of the selected fuse link, after derating at the ambient temperature of the fuse still satisfies the above criteria
- Current rating  $\leq I_z =$  array cable rating

Eaton recommends using Eaton's Bussmann series fuse links in both positive and negative cables, each with adequate voltage rating (as above). Selectivity with string fuse links may not be achieved under some fault conditions.

# Array protection — worked example

## Manufacturer's PV Module specifications

- $I_{sc} = 5.37 \text{ A}$
- $V_{oc} = 43.1 \text{ V}$
- Temperature coefficient of short-circuit current  $\alpha = 0.053 \text{ \% / } ^\circ\text{C}$

## PV Installation set-up

- Maximum irradiance level  $1000\text{W/m}^2 \geq \text{Irradiance factor } F2 = 1$
- 18 modules in series per string ( $N_s = 18$ )
- Maximum  $60^\circ\text{C}$  module Temperature factor  $F1 = 1 + \alpha \times (T - 25^\circ\text{C}) = 1.02$
- Minimum  $-30^\circ\text{C}$  module
- Maximum  $45^\circ\text{C}$  ambient fuse link. Derating factor for array fuses current carrying capability is 0.95 at  $45^\circ\text{C}$  ambient temperature
- Array cable size:  $25 \text{ mm}^2 \geq \text{cable rating } I_z = 98 \text{ A}$  at  $60^\circ\text{C}$  (Manufacturer's data)
- 8 strings in parallel ( $N_p = 8$ )
- 4 arrays in parallel ( $N_A = 4$ )

## Calculation

- Cable rating  $\geq 1.56 \times I_{sc} \times N_p$   
 $= 1.56 \times 5.37 \times 8 = 67 \text{ A}$

Selected cable  $I_z = 98 \text{ A}$  → The selected cable is suitable

- Array max short-circuit current  $I_{sc\_Array} = (N_A - 1) \times N_p \times I_{sc} \times F1 \times F2$   
 $= (4-1) \times 8 \times 5.37 \times 1.02 \times 1 = 131 \text{ A}$

- $I_{sc\_Array} (131 \text{ A}) > I_z = 98 \text{ A}$  (therefore array fuse links are required)

- Minimum fuse current rating  $I_n \geq 1.56 \times I_{sc} \times N_p$   
 $= 1.56 \times 5.37 \times 8 = 67 \text{ A}$

For PV application with fuse links installed at high altitudes, there is reduced cooling effect on the fuse as the density of the atmosphere reduces. For above 2000 metre sea level, every 100 metre increase will have 0.5% de-rate on the fuse current. Please consult Eaton's Fuse Application Engineers for further information: [bulehighspeedtechnical@eaton.com](mailto:bulehighspeedtechnical@eaton.com)

- Maximum fuse current rating:  $I_n \leq I_z = 98 \text{ A}$
- Minimum fuse voltage rating:  $U_n = 1.2 \times V_{oc} \times N_s$   
 $= 1.2 \times 43.1 \times 18 = 931 \text{ V}$

The selected fuse link needs to be rated at 80 A and 1000 V d.c. Eaton's Bussmann series part number would be PV-80ANH1 or PV-80-A-01XL. The selected fuse link has current carrying capability of  $80 \times 0.95 = 76 \text{ A}$  at  $45^\circ\text{C}$  ambient temperature, which is greater than the minimum fuse current rating (67 A).

# Solar fuse links overview

Body size	Fixings/Tags	Catalogue number	Rated voltage	Rated current	Fuse holder	Fuse bases	Fuse blocks	Fuse clips	Microswitches	Inline holders
<b>Ferrule fuse links</b>										
10x38 mm	N/A	PVM-(amps)	600 V d.c.	4 A to 30 A	CHPV		BMM	1A3400		HEB
	N/A	PV-(amps)A10F			CHPV			1A3400		HPV-DV
	Bolt	PV-(amps)A10-T	1000 V d.c.	1 A to 20 A						
	PCB (one pin)	PV-(amps)A10-1P								
	PCB (two pins)	PV-(amps)A10-2P								
	Crimp terminal	PV-(amps)A10F-CT								
10x85 mm	N/A	PV-A10F85L	1500 V d.c.	2.25 A to 30 A	CHPV15L85					
14x51 mm	N/A	PV-(amps)A14F	1100 / 1000 V d.c.	15 A to 32 A	CHPV141(I)U		FW14-PCB			
14x65 mm	N/A	PV-(amps)A14LF	1500 / 1300 V d.c.	15 A to 32 A						
	With tags	PV-(amps)A14L-T								
	With 10 mm fixings	PV-(amps)A14LF10F			CHPV15L85					
<b>NH Fuse links</b>										
1	Bladed with lugs	170M7350 to 170M7358	800 V a.c.	32 A to 200 A		SD1-D			170H0236 and 170H0238	
	Blade with bolt holes no lug	170M7353-B to 170M7358-B		63 A to 200 A						
2	Bladed with lugs	170M7397 to 170M7399	800 V a.c.	160 A to 250 A		SD2-D			170H0236 and 170H0238	
	Blade with bolt holes no lug	170M7397-B to 170M7399-B		160 A to 250 A						
3	Bladed with lugs	170M7400 to 170M7402	800 V a.c.	315 A to 400 A		SD3-D			170H0236 and 170H0238	
	Blade with bolt holes no lug	170M7400-B to 170M7402-B		315 A to 400 A						
1	Blade without bolt holes	PV-(amps)ANH1	1000 V d.c.	32 A to 200 A						
	Blade with bolt holes	PV-(amps)ANH1-B			SD1-D-PV		170H0236 and 170H238			
	Blade with bolt holes and lugs	PV-(amps)ANH1-BL								
2	Blade without bolt holes	PV-(amps)ANH2	1000 V d.c.	160 A to 250 A						
	Blade with bolt holes	PV-(amps)ANH2-B			SD2-D-PV		170H0236 and 170H238			
	Blade with bolt holes and lugs	PV-(amps)ANH2-BL								
3	Blade without bolt holes	PV-(amps)ANH3	1000 V d.c.	300 A to 400 A						
	Blade with bolt holes	PV-(amps)ANH3-B			SD3-D-PV		170H0236 and 170H238			
	Blade with bolt holes and lugs	PV-(amps)ANH3-BL								
<b>Flush end</b>										
2	N/A	PV-(amp)AF2	1000 V d.c.	160 A to 250 A						
3	N/A	PV-(amp)AF3		315 A to 400 A						
<b>XL Fuse links</b>										
01XL	Bladed	PV-(amps)A-01XL	1000 V d.c.	63 A to 160 A		SD1XL-S-PV			170H0236 and 170H0238	
	Bolted	PV-(amps)A-01XL-B						170H0069		
2	Bladed	PV-(amps)A-2XL	1000 V d.c.	160 A to 355 A		SD2XL-S-PV			170H0236 and 170H0238	
	Bolted	PV-(amps)A-2XL-B						170H0069		
		PV-(amps)A-2XL-3B								
3	Bladed	PV-(amps)A-3L	1000 V d.c.	350 A to 600 A		SD3L-S-PV			170H0236 and 170H0238	
	Bolted	PV-(amps)A-3L-B						170H0069		
01	Bladed with top indicator	PV-(amps)A-01XL-15	1500 V d.c.	50 A to 125 A		SD1XL-S-PV			170H0236 and 170H0238	
	Bolted with side indicator	PV-(amps)A-01XL-B-15						170H0069		
1	Bladed with top indicator	PV-(amps)A-1XL-15	1500 V d.c.	100 A to 200 A		SD1XL-S-PV			170H0236 and 170H0238	
	Bolted with side indicator	PV-(amps)A-1XL-B-15						170H0069		
2	Bladed with top indicator	PV-(amps)A-2XL-15	1500 V d.c.	125 A to 250 A		SD2XL-S-PV			170H0236 and 170H0238	
	Bladed without top indicator	PV-(amps)A-2XL-U-15								
	Bolted with side indicator	PV-(amps)A-2XL-B-15						170H0069		
		PV-(amps)A-2XL-3B-15								
	Bolted without side indicator	PV-(amps)A-2XL-BU-15 PV-(amps)A-2XL-3BU-15								
3	Bladed with top indicator	PV-(amps)A-3L-15	1500 V d.c.	250 A to 500 A		SD3L-S-PV			170H0236 and 170H0238	
	Bladed without top indicator	PV-(amps)A-3L-U-15								
	Bolted with side indicator	PV-(amps)A-3L-B-15						170H0069		
	Bolted without side indicator	PV-(amps)A-3L-BU-15								

# PVM, 10 x 38 mm photovoltaic fuse links, 4 to 30 A, 600 V d.c.

## Description

A range of UL 2579 fast-acting 600 V d.c. Midget fuses specifically designed to protect solar power systems in extreme ambient temperature, high cycling and low level fault current conditions (reverse current, multi-array fault).



## Catalogue number

PVM-(amp rating)

## Technical data

Fuse size: 10 x 38 mm

Rated voltage: 600 V d.c. to UL 2579

Rated current: 4 A to 30 A

Interrupting rating: 50 kA DC

## Standard/Approvals

UL Listed 2579, Guide JFGA, File E335324

CSA Component Certified C22.2

## Packaging

10

## Recommended fuse blocks / fuse holders

Fuse blocks: BMM (data sheet 10241)

Modular fuse holder: CHPV (data sheet 720147)

Fuseclips: 1A3400 Series (data sheet 2131)

In-line fuse holders: HEB (data sheets 2127)



BMM



CHPV



1A3400



HEB

## Technical data

Catalogue number	Rated current (A)	Rated voltage (V d.c.)	Power loss (Watts)		Compatible fuse blocks	Compatible modular fuse holders	Compatible fuse clips	Compatible in-line fuse holders
			0.8 I <sub>n</sub>	I <sub>n</sub>				
PVM-4	4	600 (UL)			BMM	CHPV	1A3400	HEB
PVM-5	5							
PVM-6	6							
PVM-7	7							
PVM-8	8							
PVM-9	9							
PVM-10	10		1	1.9				
PVM-12	12							
PVM-15	15		1	1.7				
PVM-20	20							
PVM-25	25							
PVM-30	30		1.6	2.9				

Data sheet: 2153

# PVM, 10 x 38 mm photovoltaic fuse links, 4 to 30 A, 600 V d.c.

## Dimensions in (mm)

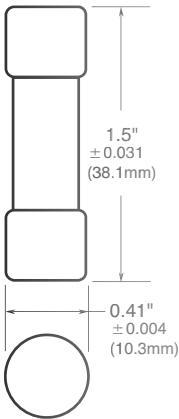

## Time current curve

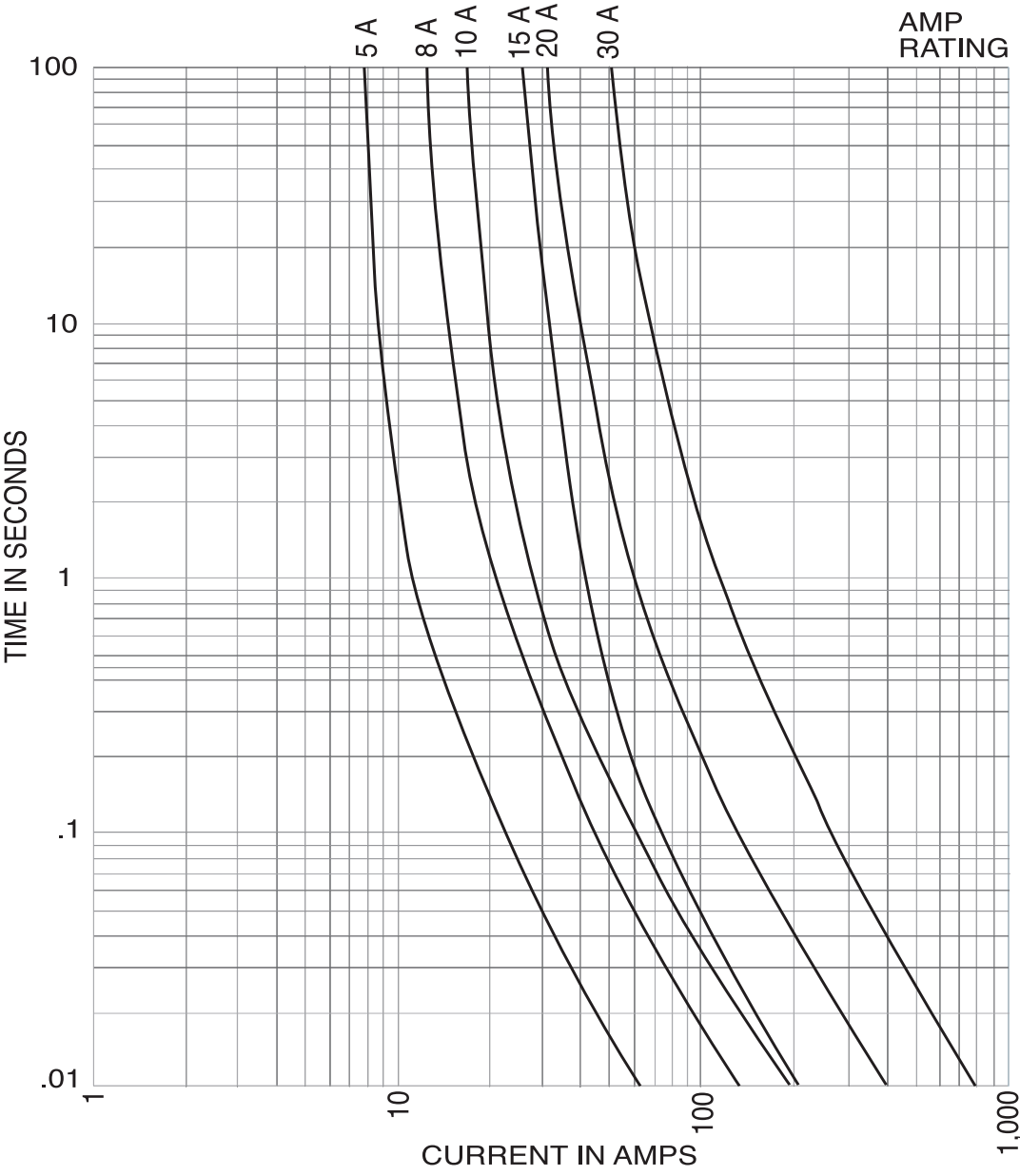

Please contact [FUSETECH@eaton.com](mailto:FUSETECH@eaton.com) for further information

Data sheet: 2153

# PV-A10, 10 x 38 mm photovoltaic fuse links, 1 to 20 A, 1000 V d.c.

## Description

A range of fuse links in a 10 x 38 mm package specifically designed for the protection and isolation of photovoltaic strings. The fuse links are capable of interrupting low overcurrents associated with faulted PV (reverse current, multi-array fault) strings.

## Catalogue number

Cylindrical: PV-(amp rating)A10F

Bolt fixing: PV-(amp rating)A10-T

PCB fixing 1 pin: PV-(amp rating)A10-1P

PCB fixing 2 pin: PV-(amp rating)A10-2P

PCB fixing double pin sliver cap: PV-(amp rating)A10-2PS

In-line with crimp terminal: PV-(amp rating)A10F-CT



## Technical data

Fuse size: 10 x 38 mm

Rated voltage: 1000 V d.c.

Rated current: 1 A to 20 A

Breaking capacity: 50 kA

Operating class: gPV and UL PV Fuse links

Min interrupting rating:  $1.3 \times I_n$  for 1 to 15 A,  $1.5 \times I_n$  for 20 A

Time constant: 1 - 3 ms

PV Fuse coordination with thin film cells and 4" 5" and 6" crystalline silicon cells

## Standards/Approvals

IEC 60269-6

UL 2579 (File number E335324)

CCC (1 to 15A), RoHS compliant

## Packaging

MOQ: 10

Packaging 100% recyclable

## Recommended fuse holders and clips

See table

# PV-A10, 10 x 38 mm photovoltaic fuse links, 1 to 20 A, 1000 V d.c.

## Technical data - Cylindrical, Bolt fixing and In-line with crimp terminal

Rated voltage	Rated current (Amps)	I <sup>2</sup> t (A <sup>2</sup> Sec)		Watts loss (W)		Catalogue numbers		
		Pre-arcing	Total at 1000 V d.c.	0.8 I <sub>n</sub>	I <sub>n</sub>	Cylindrical	Bolt fixing	In-line with crimp terminal
1000 V d.c. (UL/IEC)	1	0.2	0.4	0.8	1.5	PV-1A10F	PV-1A10-T	PV-1A10F-CT
	2	1.2	4	0.6	1.0	PV-2A10F	PV-2A10-T	PV-2A10F-CT
	2.5	3	9	0.6	1.0	PV-2-5A10F	PV-2-5A10-T	PV-2-5A10F-CT
	3	4	11	0.8	1.3	PV-3A10F	PV-3A10-T	PV-3A10F-CT
	3.5	6.6	18	0.9	1.4	PV-3-5A10F	PV-3-5A10-T	PV-3-5A10F-CT
	4	9.5	26	1.0	1.5	PV-4A10F	PV-4A10-T	PV-4A10F-CT
	5	19	50	1.0	1.6	PV-5A10F	PV-5A10-T	PV-5A10F-CT
	6	30	90	1.1	1.8	PV-6A10F	PV-6A10-T	PV-6A10F-CT
	8	3	32	1.2	2.1	PV-8A10F	PV-8A10-T	PV-8A10F-CT
	10	7	70	1.2	2.3	PV-10A10F	PV-10A10-T	PV-10A10F-CT
	12	12	120	1.5	2.7	PV-12A10F	PV-12A10-T	PV-12A10F-CT
	15	15	160	1.7	2.9	PV-15A10F	PV-15A10-T	PV-15A10F-CT
	16	19	200	1.8	3	PV-16A10F	PV-16A10-T	PV-16A10F-CT
	20	34	350	2.1	3.6	PV-20A10F	PV-20A10-T	PV-20A10F-CT



Cylindrical



With bolt fixing



In-line with crimp terminal

## Technical data - PCB

Rated voltage	Rated current (Amps)	I <sup>2</sup> t (A <sup>2</sup> Sec)		Watts loss (W)		Catalogue numbers		
		Pre-arcing	Total at 1000 V d.c.	0.8 I <sub>n</sub>	I <sub>n</sub>	PCB fixing single pin	PCB fixing double pin	PCB fixing double pin silver cap
1000 V d.c. (UL/IEC)	1	0.2	0.4	0.8	1.5	PV-1A10-1P	PV-1A10-2P	PV-1A10-2P-S
	2	1.2	4	0.6	1.0	PV-2A10-1P	PV-2A10-2P	PV-2A10-2P-S
	2.5	3	9	0.6	1.0	PV-2-5A10-1P	PV-2-5A10-2P	PV-2-5A10-2P-S
	3	4	11	0.8	1.3	PV-3A10-1P	PV-3A10-2P	PV-3A10-2P-S
	3.5	6.6	18	0.9	1.4	PV-3-5A10-1P	PV-3-5A10-2P	PV-3-5A10-2P-S
	4	9.5	26	1.0	1.5	PV-4A10-1P	PV-4A10-2P	PV-4A10-2P-S
	5	19	50	1.0	1.6	PV-5A10-1P	PV-5A10-2P	PV-5A10-2P-S
	6	30	90	1.1	1.8	PV-6A10-1P	PV-6A10-2P	PV-6A10-2P-S
	8	3	32	1.2	2.1	PV-8A10-1P	PV-8A10-2P	PV-8A10-2P-S
	10	7	70	1.2	2.3	PV-10A10-1P	PV-10A10-2P	PV-10A10-2P-S
	12	12	120	1.5	2.7	PV-12A10-1P	PV-12A10-2P	PV-12A10-2P-S
	15	15	160	1.7	2.9	PV-15A10-1P	PV-15A10-2P	PV-15A10-2P-S
	16	19	200	1.8	3	PV-16A10-1P	PV-16A10-2P	PV-16A10-2P-S
	20	34	350	2.1	3.6	PV-20A10-1P	PV-20A10-2P	PV-20A10-2P-S



PCB 1 Pin



PCB 2 Pin

# PV-A10, 10 x 38 mm photovoltaic fuse links, 1 to 20 A, 1000 V d.c.

## Compatible fuse holders and clips

Rated voltage	Fuse type	Compatible in-line holders	Compatible modular fuse holders	Compatible fuse clips	
1000 V d.c.	Cylindrical	PV-1A10F	HPV-DV-**	CHPV	1A3400
		PV-2A10F	HPV-DV-**	CHPV	1A3400
		PV-2-5A10F	HPV-DV-**	CHPV	1A3400
		PV-3A10F	HPV-DV-**	CHPV	1A3400
		PV-3-5A10F	HPV-DV-**	CHPV	1A3400
		PV-4A10F	HPV-DV-**	CHPV	1A3400
		PV-5A10F	HPV-DV-**	CHPV	1A3400
		PV-6A10F	HPV-DV-**	CHPV	1A3400
		PV-8A10F	HPV-DV-**	CHPV	1A3400
		PV-10A10F	HPV-DV-**	CHPV	1A3400
		PV-12A10F	HPV-DV-**	CHPV	1A3400
		PV-15A10F	HPV-DV-**	CHPV	1A3400
		PV-16A10F	HPV-DV-**	CHPV	1A3400
		PV-20A10F	HPV-DV-**	CHPV	1A3400

Please note no fuse holders and/or clips are compatible with the Bolt fixing, in-line crimp terminal and PCB fixings versions

## Dimensions (mm) Cylindrical PV-\*\*A10F

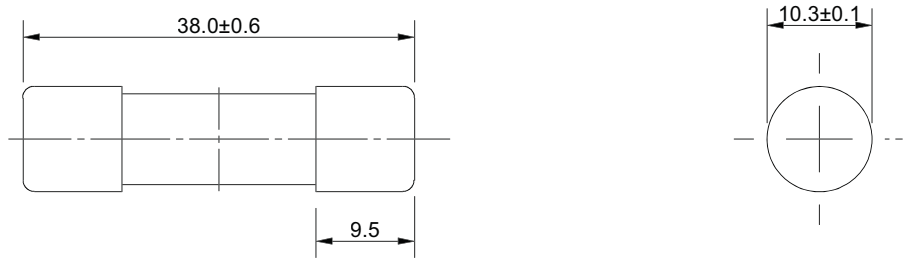

## Dimensions (mm) PCB fixing PV-\*\*A10-xP

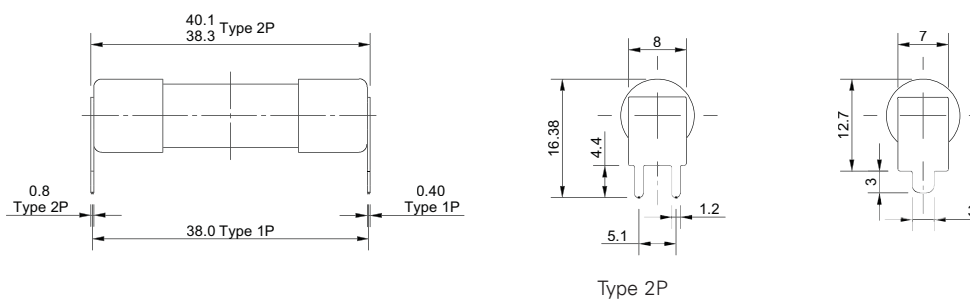

## Dimensions (mm) Bolt fixing PV-\*\*A10-T

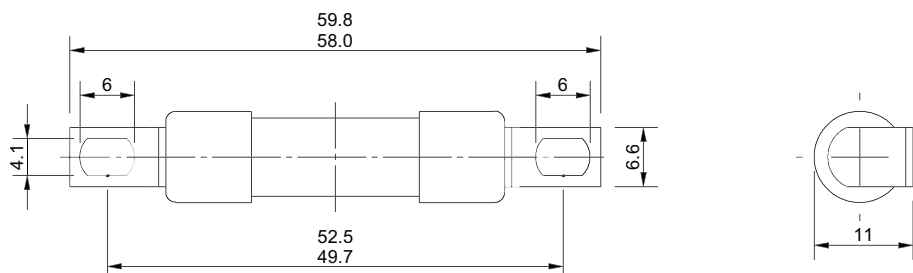

# PV-A10, 10 x 38 mm photovoltaic fuse links, 1 to 20 A, 1000 V d.c.

## Dimensions (mm) In-line with crimp terminal PV-\*\*A10F-CT

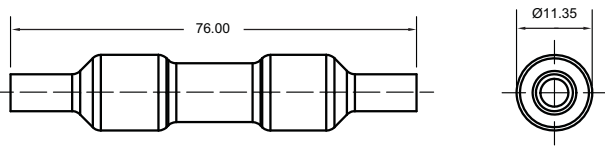

The in-line crimp terminal version can be electrically insulated with customer supplied overmolding or approved heat-shrink.

### Operating temperature range

- -40°C to 90°C

### Wire range and type

- Single conductor, 12-10AWG 75°C/90°C Cu stranded PV

### Overmolding temperature parameters

- 233°C for 180 sec Max

### Terminals

- Crimp terminal for 12-10AWG PV copper conductors

### Recommended tools

- Sta-Kon® terminal crimping tool, catalog number ERG4002

## Time current curve

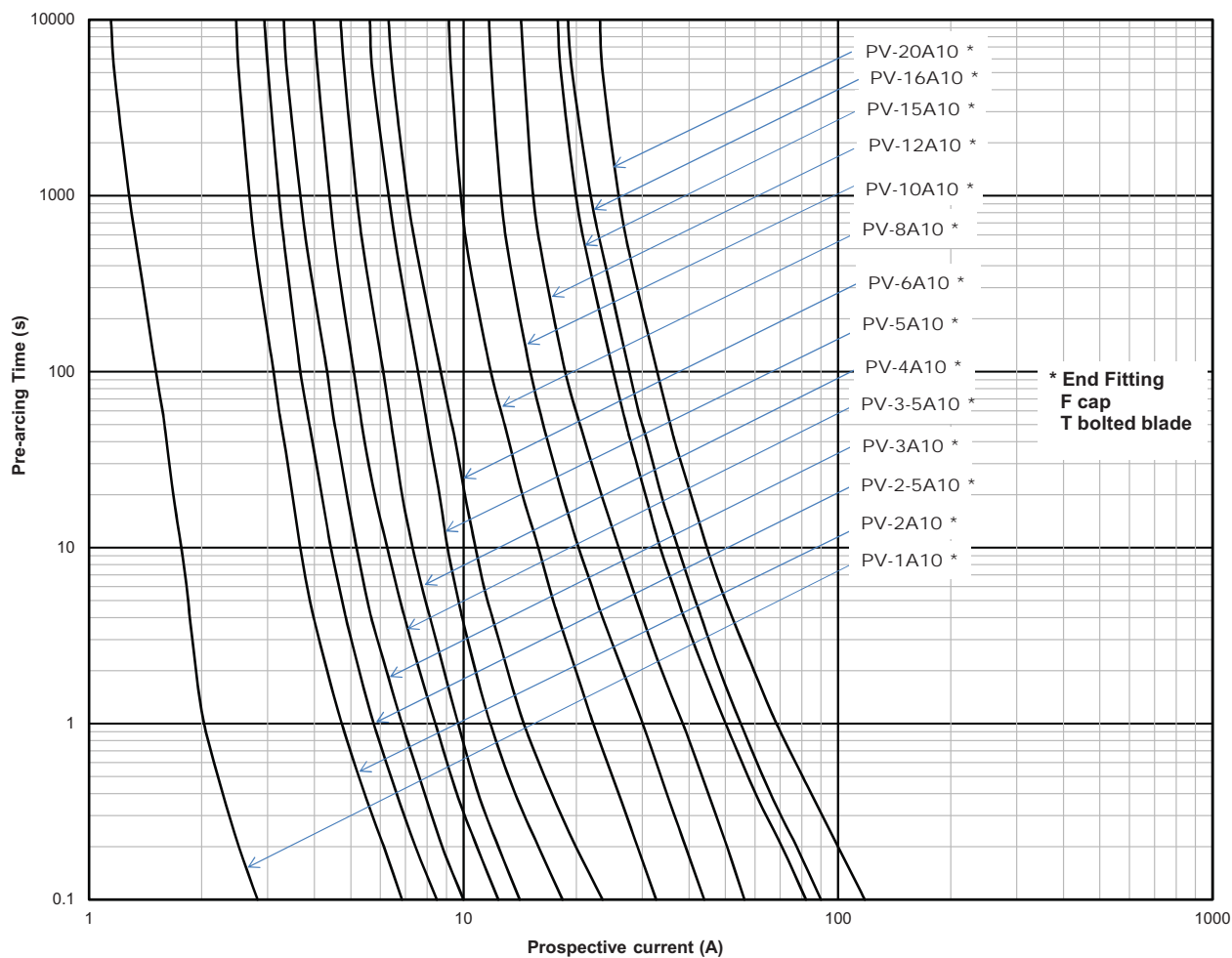

# PV-A10, 10 x 38 mm photovoltaic fuse links, 1 to 20 A, 1000 V d.c.

## Temperature derating

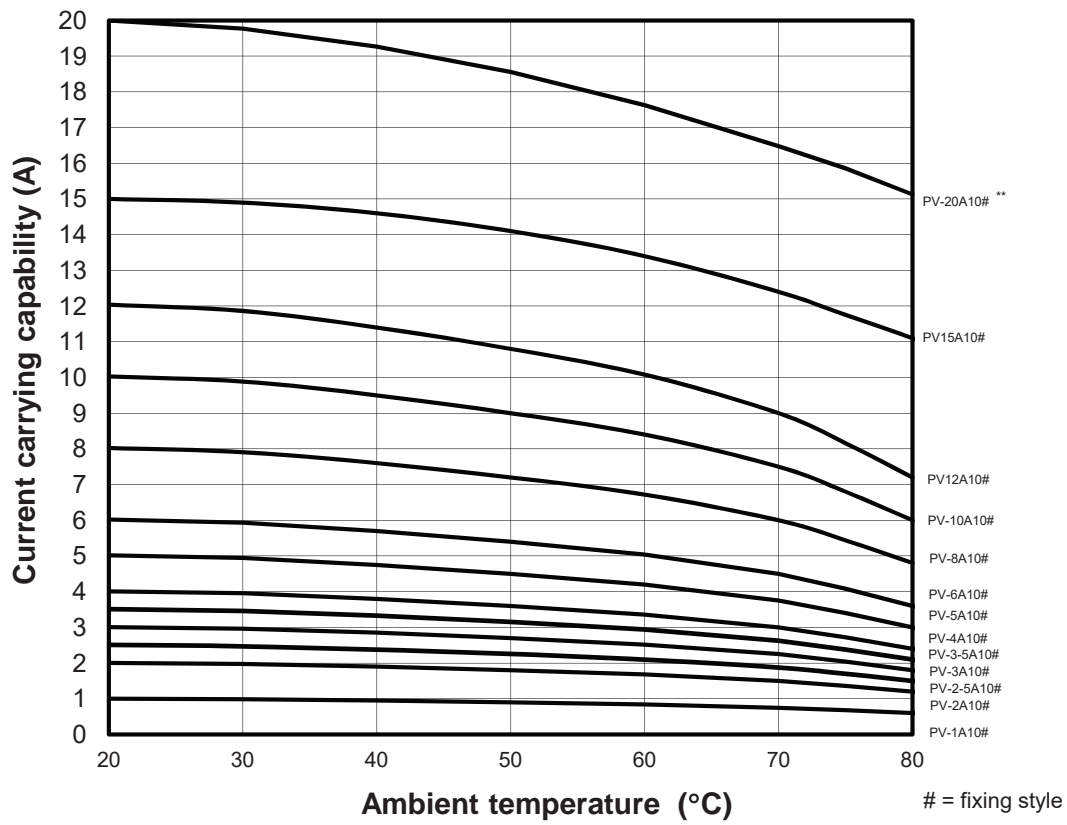

Data sheet: 720110

Data sheet: 720110

# CHPV, Modular fuse holders 32A (IEC), 30 A (UL), 1000 V d.c.

## Description

Compact DIN-Rail mounting fuse holders specifically designed for 10 x 38 mm cylindrical photovoltaic fuse links.



## Catalogue numbers

CHPV1U 1-pole modular fuse holder

CHPV2U 2-pole modular fuse holder

CHPV11U 1-pole modular fuse holder with neon indicator

CHPV21U 2-pole modular fuse holder with neon indicator

## Technical data

IEC		UL		Terminal rating	Rated breaking withstand capacity	Compatible Busmann series fuse links
Rated voltage	Rated current	Rated voltage	Rated current			
1000 V d.c.	32 A	1000 V d.c.	30 A	IEC 1 to 25 mm <sup>2</sup> 70°C PVC Copper cable (solid stranded or fine stranded) Spade lug Comb bus bar	33 kA rms sym	Solar PV range: PVM, PV-A10F Cylindrical

## Standards / Agency information

IEC	UL	CSA	CCC	CE
IEC 60269-1	UL 4248-1 UL4248-19 UL file E14853	C22.2 No 4248.1 C22.2 No 4248.19	GB 13539.1	DCB 272

## Dimensions mm (in)

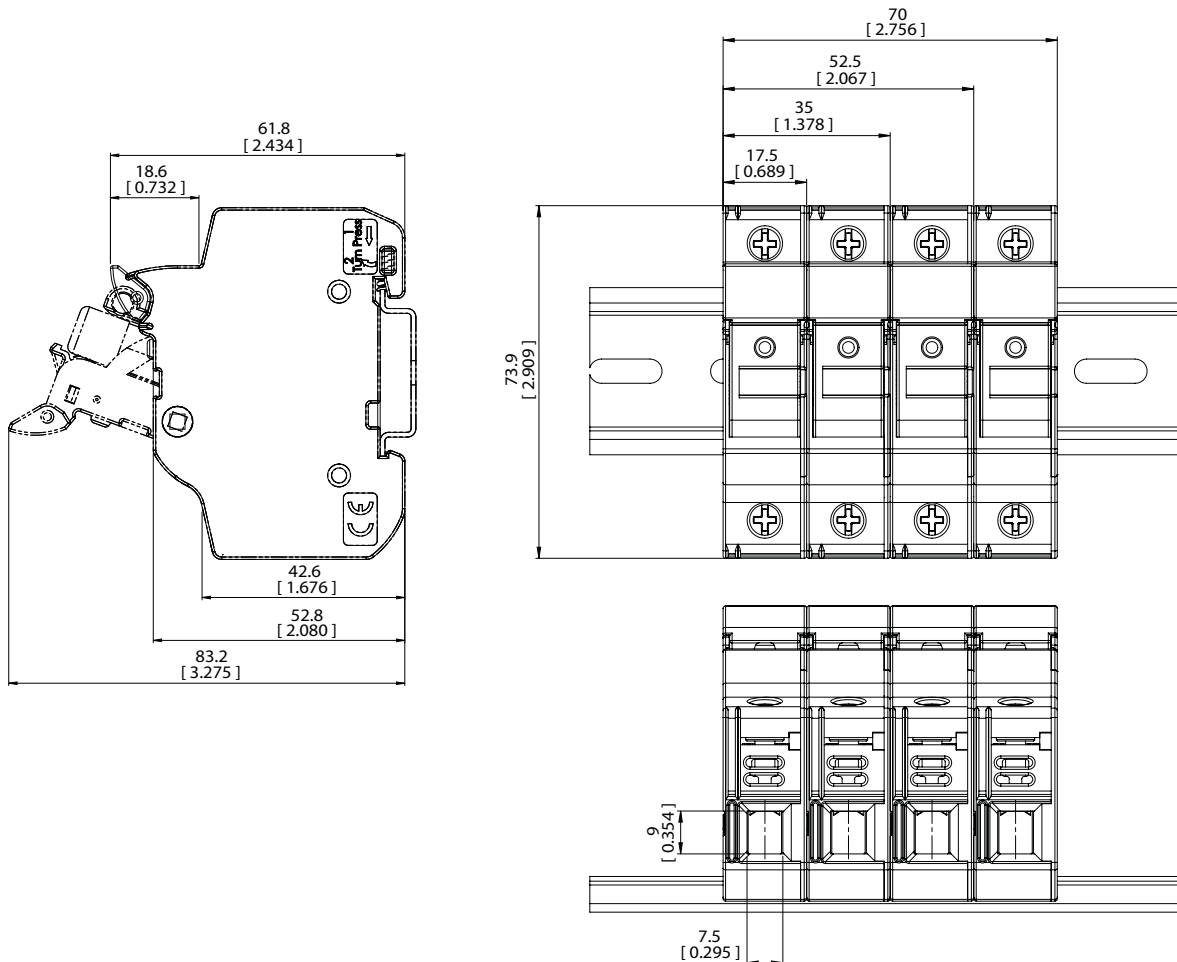

# PV-A10F85L, 10 x 85 mm photovoltaic fuse links, 2.25 to 30 A, 1500 V d.c.

## Description

A range of fuse links in a 10 x 85 mm package specifically designed for the protection and isolation of photovoltaic strings.

## Catalogue number

PV-(amp rating)A10F85L

## Technical data

Fuse size: 10 x 85 mm

Rated voltage: 1500 V d.c.

Rated current: 2.25 A to 30 A

Breaking capacity: 30 kA at 1 ms

Operating class: gPV

## Standards/Approvals

IEC 60269-6

UL 248-19

RoHS compliant

## Packaging

MOQ: 10

Packaging 100% recyclable

## Recommended fuse holder

CHPV15L85 (see page 25)



## Technical data

Rated voltage	Rated current (Amps)	$I^2t$ (A <sup>2</sup> Sec)		Watts loss (W)		Catalogue numbers	Compatible fuse holder
		Pre-arcing	Total at 1500 V d.c.	0.8 $I_n$	$I_n$		
1500 V d.c. (IEC/UL)	2.25	3	10	1.4	2.4	PV-2-25A10F85L	CHPV15L85
	2.5	4	10	1.3	2.1	PV-2.5A10F85L	CHPV15L85
	3	7	20	1.3	2.2	PV-3A10F85L	CHPV15L85
	3.5	10	20	1.6	2.6	PV-3.5A10F85L	CHPV15L85
	4	15	30	1.7	2.8	PV-4A10F85L	CHPV15L85
	5	33	60	1.7	2.8	PV-5A10F85L	CHPV15L85
	12	19	240	2.1	3.5	PV-12A10F85L	CHPV15L85
	15	42	300	2.2	3.6	PV-15A10F85L	CHPV15L85
	16	48	350	2.1	3.5	PV-16A10F85L	CHPV15L85
	20	108	800	2.7	4.5	PV-20A10F85L	CHPV15L85
	25	190	1400	3.4	5.6	PV-25A10F85L	CHPV15L85
	30	485	3500	4	6.6	PV-30A10F85L	CHPV15L85

## Dimensions (mm)

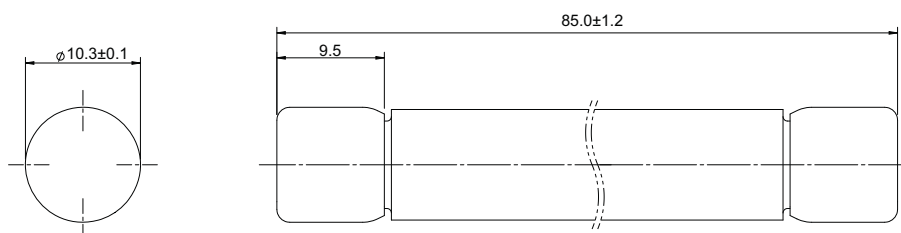

# PV-A10F85L, 10 x 85 mm photovoltaic fuse links, 2.25 to 30 A, 1500 V d.c.

## Time current curve

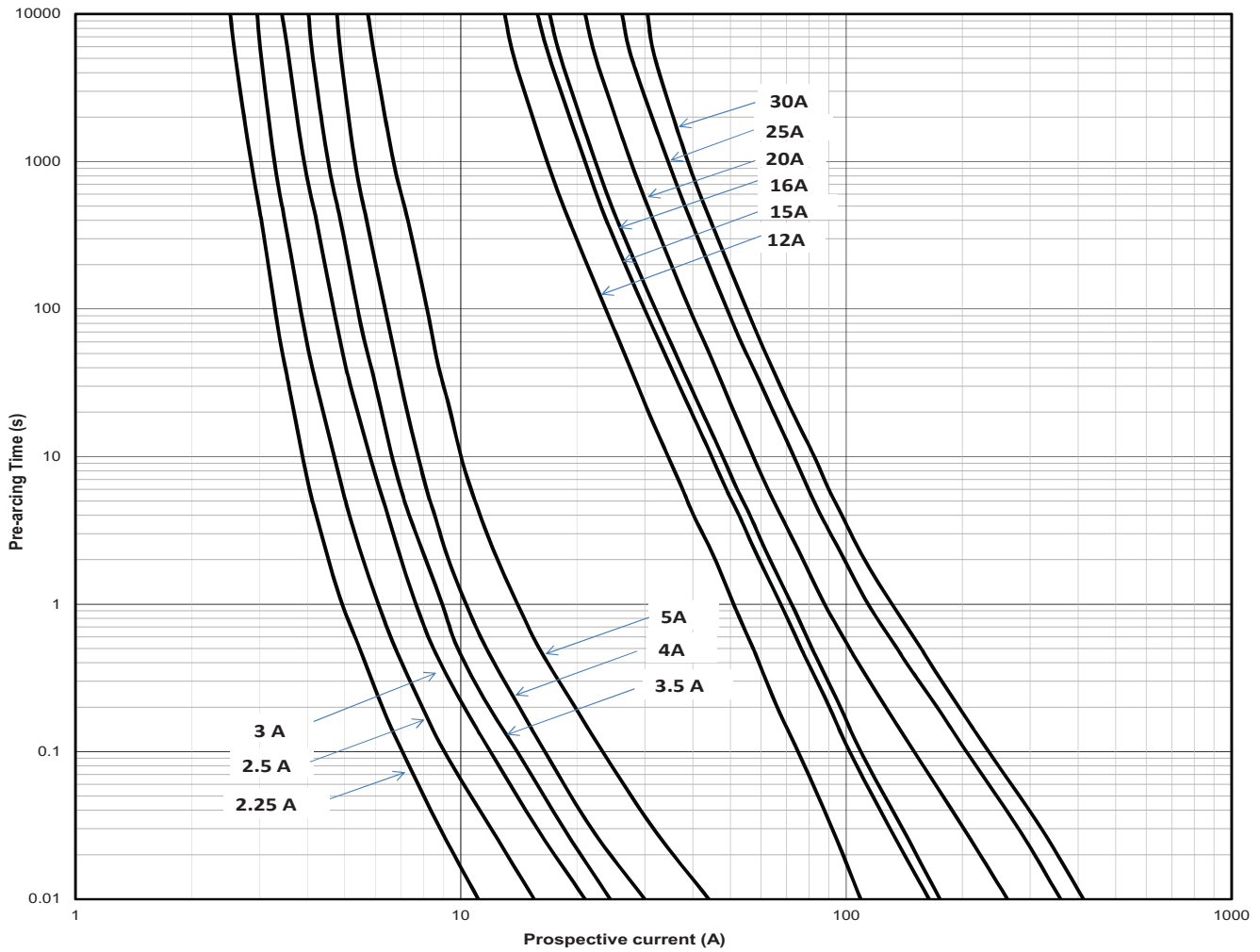

# CHPV15L85, photovoltaic fuse holder, 32 A (IEC/UL) 1500 V d.c.

## Description

Eaton's Bussmann series 10 x 85 mm fuse holders are suitable for use with 10 x 85 mm and 14 x 85 mm cylindrical gPV fuse links. The unique design offers high degree of safety. There is no possibility of any accidental contact with live parts during replacement of the fuse links. When the fuse carrier is extracted, a spring loaded cover moves out covering the live parts hence protecting against accidental damage.

## Catalogue number

CHPV15L85

## Technical data

Rated voltage: 1500 V d.c.

Rated current: 32 A

Breaking capacity: 50 kA

Operating class: gPV

## Standards/Approvals

IEC 60269-1

UL 4248 Edition 1 (File number 348242)

UL 4248-19 Edition 1

## Packaging

MOQ: 10

## Compatible fuse links

10 x 85 mm fuse links: PV-A10F85L (see page 23)

14 x 85 mm fuse links: PV-A14LF (see page 30)



## Dimensions (mm)

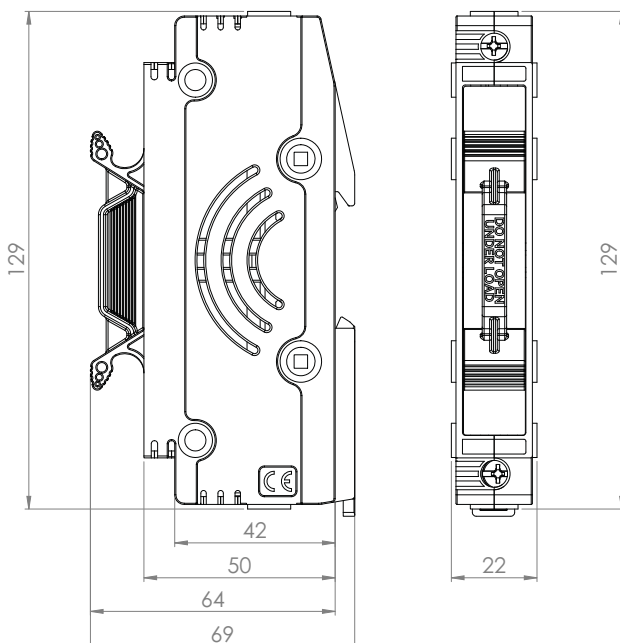

# PV-14AF, 14 x 51 mm photovoltaic fuse links, 15 to 32 A, 1000/1100 V d.c.

## Description

A range of 14 x 51 mm fuse links specifically designed for protecting and isolating photovoltaic strings. These fuse links are capable of interrupting low overcurrents associated with faulted PV systems (reverse current, multi-array fault).

## Catalogue number

PV-(amp rating)A14F

## Technical data

Fuse size: 14 x 51 mm

Rated voltage:

- 1100 V d.c. (IEC and UL for 15 A and 20 A)
- 1000 V d.c. (IEC and UL for 25 and 32 A)

Rated current: 15, 20, 25 and 32 A

Breaking capacity: 30 kA

Operating class: gPV and UL PV Fuse links



## Standards / Approvals

IEC 60269-6

UL 2579 (File number E335324)

RoHS compliant

## Packaging

MOQ: 10

Packaging 100% recyclable.

## Recommended modular fuse holders

- Without indicator: CHPV141U
- With indicator: CHPV141IU

See page 28

## Recommended modular fuse clips

FW14-PCB

## Catalogue numbers

Catalogue number	Rated current (Amps)	Rated voltage (V d.c.)	Energy integrals I <sup>2</sup> t (A <sup>2</sup> s)		Watts loss		Compatible modular fuse holder		
			Pre-arcing	Total at rated voltage	08 I <sub>n</sub>	I <sub>n</sub>	Without indicator	With indicator	Compatible fuse clip
PV-15A14F	15	1100	14	265	2.1	4	CHPV141U	CHPV141IU	FW14-PCB
PV-20A14F	20	1100	27	568	2.7	5	CHPV141U	CHPV141IU	FW14-PCB
PV-25A14F	25	1000	65	943	2.7	5.1	CHPV141U	CHPV141IU	FW14-PCB
PV-32A14F	32	1000	120	1740	3.3	6.2	CHPV141U	CHPV141IU	FEW14-PCB

## Dimensions (mm)

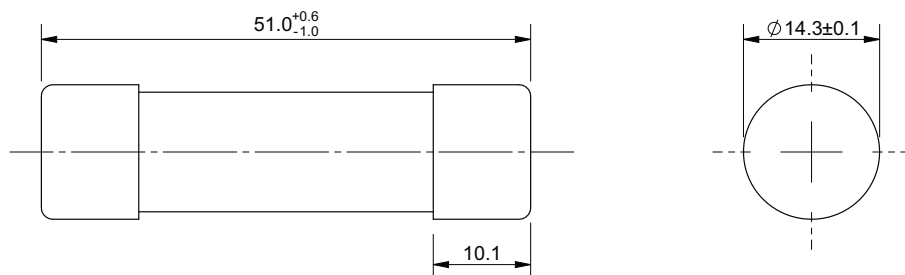

Data sheet: 720132

# PV-14AF, 14 x 51 mm photovoltaic fuse links, 15 to 32 A, 1000/1100 V d.c.

## Time current curve

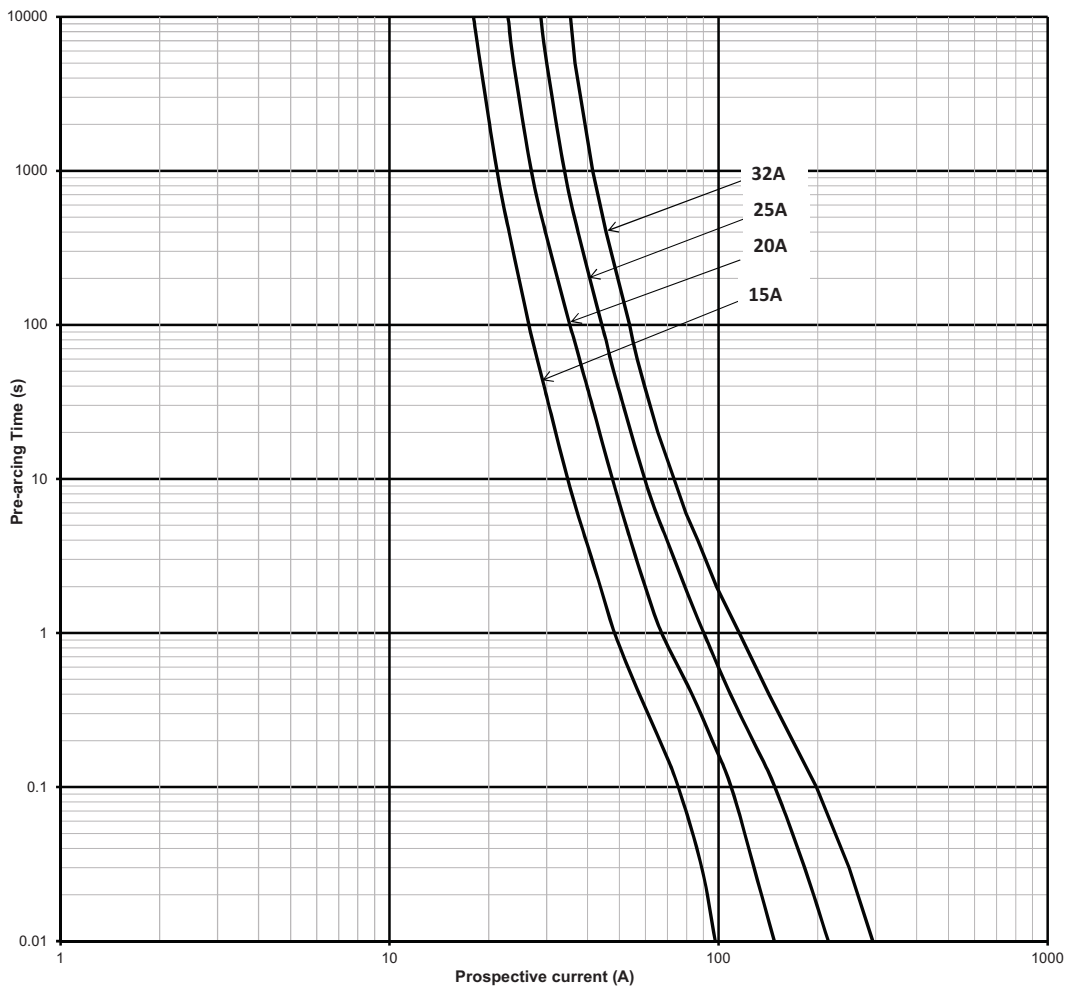

# CHPV14, 14 x 51 mm modular fuse holders, 50 A, 1500 V d.c.

## Description

Compact DIN-Rail mounting fuse holders specifically designed for 14 x 51 mm photovoltaic fuse links.



## Catalogue number

CHPV141U 1-pole without indicator

CHPV142 2-pole without indicator

CHPV141IU 1-pole with indicator

CHPV142IU 2-pole with indicator

## Technical data

IEC		UL		Agency markings	Terminal rating	Rated breaking withstand capacity	Compatible Busmann series fuse links
Rated voltage	Rated current	Rated voltage	Rated current				
1500 V d.c.	1500 V d.c.	50 A (a.c. and d.c.)	50 A	IEC 60269-1 and 2 UL Listed file number E348242	Cable size: 1.5-50 mm <sup>2</sup> Recommended torque setting: 3.5 Nm Maximum torque setting: 3.5 Nm Mounting 35 mm DIN-Rail or 2 x M4 panel mounting screws	10 kA d.c.	PV-A14F

## Standards / Approvals

IEC 60269-1 and 2

UL Listed number E348242

## Packaging

MOQ: 10

Packaging 100% recyclable

## Accessories

Catalogue numbers	Description	Unit packing
JV-L	Multi-pole connector kit. One kit will gang up to 4-poles together	12
CH14-CTP	IP20 Protection accessory, provides IP20 protection to terminals with 10mm <sup>2</sup> or less cable	12

## Dimensions - mm

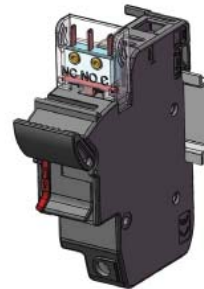
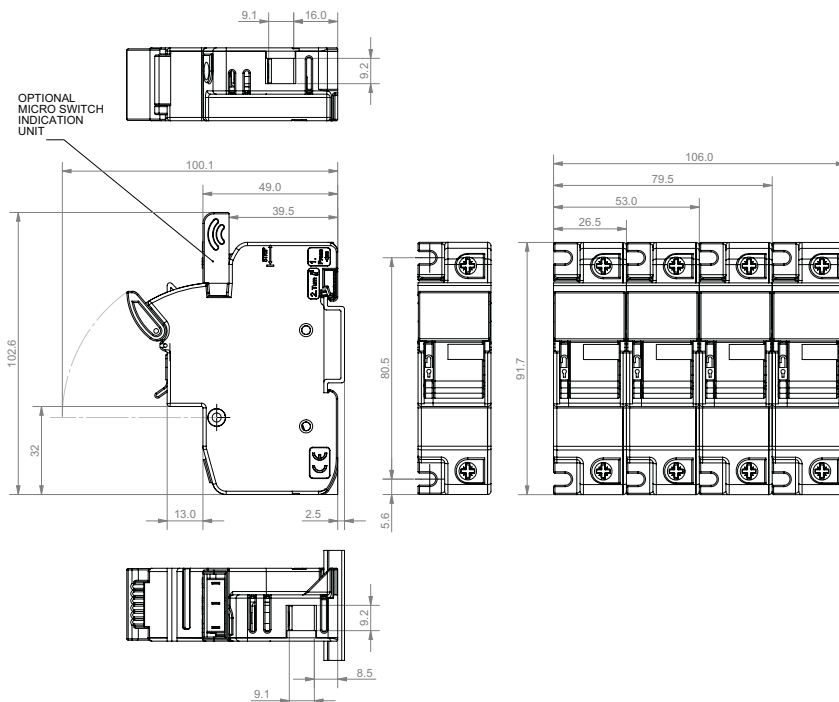

Data sheet: 10080

# FW14-PCB, Mountable fuse clips

## Description

Compatible with our 14 x 51 mm PV-(amps)A14F fuse links

Please note deratings apply to fuse links with watts loss greater than 6 Watts, contact [bulehighspeedtechnical@eaton](mailto:bulehighspeedtechnical@eaton) for application assistance.

## Catalogue number

FW14-PCB

## Technical data

Maximum rated power acceptance: 6 Watts

Material: Copper Alloy CuSn

Tin plated

Weight: 5 grams each

Standard: IEC 60269-1

Pack quantity: 500

## Dimensions - mm

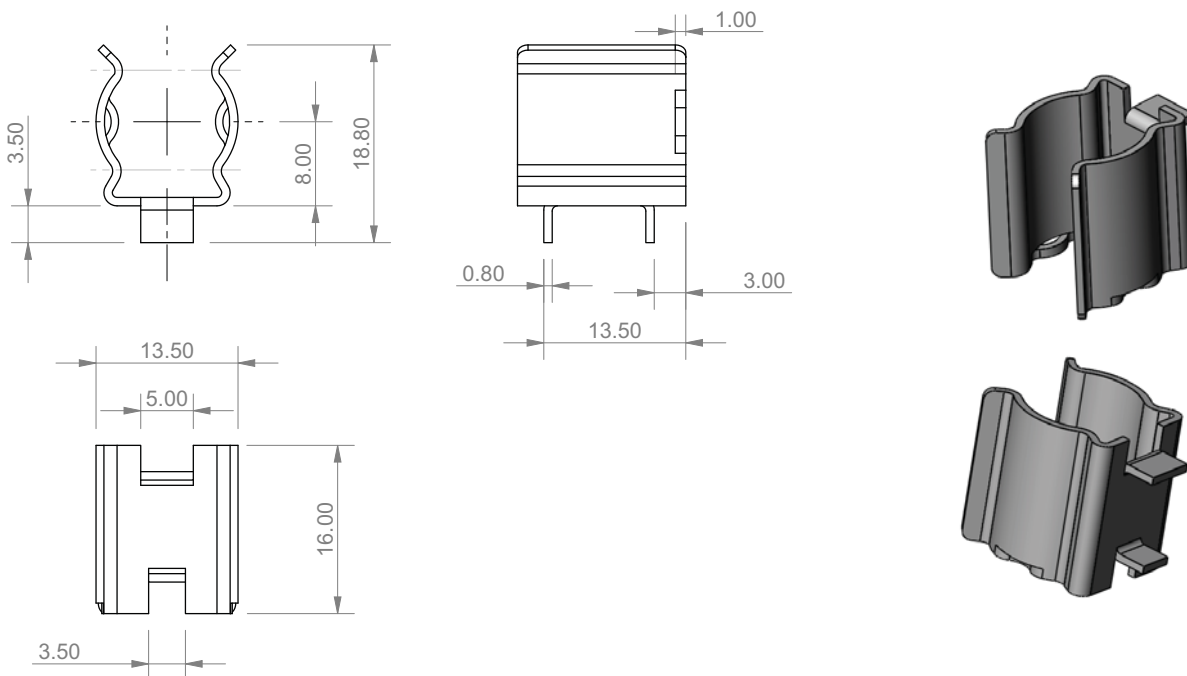

Note : Appropriate creepage and clearances distances between clips should be maintained when mounting on the PCB.

# PV-A14L, 14 x 65 mm photovoltaic fuse links, 3.5 to 32 A, 1300/1500 V d.c.

## Description

A range of 14 x 65mm fuse links specifically designed for protecting and isolating photovoltaic strings. These fuse links are capable of interrupting low overcurrents associated with faulted PV systems (reverse current, multi-array fault).



## Catalogue number

Cylindrical: PV-(amp rating)A14LF

Cylindrical with tags: PV-(amp rating)A14L-T

Cylindrical with 10mm fixings: PV-(amp rating)A14LF10F

## Technical data

Fuse size: 14 x 65 mm

Rated current:

- 1500 V d.c. (IEC and UL, 2.25 A to 20 A)
- 1300 V d.c. (IEC and UL, 25 A and 32 A)

Rated current: 2.25 A to 32 A

Rated breaking capacity: 10 kA

Operating class: gPV and UL PV Fuse links

Minimum interrupting rating: 2 x I<sub>n</sub>

PV Fuse coordination w/ Thin film cells 4", 5" and 6" crystalline

Time constant: 1-3 ms

## Standards / Approvals

IEC 60269-6, UL 2579

(File number E335324)

RoHS compliant

## Packaging

MOQ: 10

Packaging 100% recyclable.

## Recommended fuse holders and clips

See table page 31

## Technical data

Rated voltage	Rated current (Amps)	I <sup>2</sup> t (A <sup>2</sup> Sec)		Watts loss (W)		Catalogue numbers		
		Pre-arcing	Total at rated voltage	0.8 I <sub>n</sub>	I <sub>n</sub>	Cylindrical	Cylindrical with tags	Cylindrical with 10mm fixings
1500 V d.c. (IEC/UL)	2.25	4	8	1.4	2.3	PV-2.25A14LF	N/A	PV-2.25A14LF10F
	2.5	5	10	1.5	2.5	PV-2.5A14LF	PV-2.5A14L-T	PV-2.5A14LF10F
	3	8	14	1.7	2.8	PV-3A14LF	PV-3A14L-T	PV-3A14LF10F
	3.5	12	23	1.8	3.0	N/A	N/A	PV-3.5A14LF10F
	4	18	34	2	3.3	PV-4A14LF	PV-4A14L-T	PV-4A14LF10F
	15	16	190	2.9	5.1	PV-15A14LF	PV-15A14L-T	PV-15A14LF10F
	20	34	400	3.8	6.9	PV-20A14LF	PV-20A14L-T	PV-20A14LF10F
1300 V d.c. (IEC/UL)	25	65	550	4.1	7.5	PV-25A14LF	PV-25A14L-T	PV-25A14LF10F
	32	105	900	5.7	10.4	PV-32A14LF	PV-32A14L-T	PV-32A14LF10F

Data sheet: 720139

# PV-A14L, 14 x 65 mm photovoltaic fuse links, 3.5 to 32 A, 1300/1500 V d.c.

## Compatible fuse holders and fuse clips

Rated voltage	Fuse type	Catalogue numbers	Compatible fuse holders	Compatible fuse clips	
1500 V d.c.	Cylindrical	PV-2.25A14LF		5592-01	
		PV-2.5A14LF		5592-01	
		PV-3A14LF		5592-01	
		PV-4A14LF		5592-01	
		PV-15A14LF		5592-01	
		PV-20A14LF		5592-01	
1300 V d.c.		PV-25A14LF		5592-01	
		PV-32A14LF		5592-01	
1500 V d.c.	Cylindrical with tags	PV-2.5A14L-T			
		PV-3A14L-T			
		PV-4A14L-T			
		PV-15A14L-T			
		PV-20A14L-T			
		1300 V d.c.			PV-25A14L-T
PV-32A14L-T					
1500 V d.c.	Cylindrical with 10 mm fixings	PV-2.25A14LF10F	CHPV15L85		5960-07 and 5960-09
		PV-2.5A14LF10F	CHPV15L85		5960-07 and 5960-09
		PV-3A14LF10F	CHPV15L85		5960-07 and 5960-09
		PV-3.5A14LF10F	CHPV15L85		5960-07 and 5960-09
		PV-4A14LF10F	CHPV15L85		5960-07 and 5960-09
		PV-15A14LF10F	CHPV15L85	5960-07 and 5960-09	
		PV-20A14LF10F	CHPV15L85	5960-07 and 5960-09	
		1300 V d.c.		PV-25A14LF10F	CHPV15L85
PV-32A14LF10F	CHPV15L85			5960-07 and 5960-09	

## Dimensions (mm) Cylindrical PV-\*A14LF

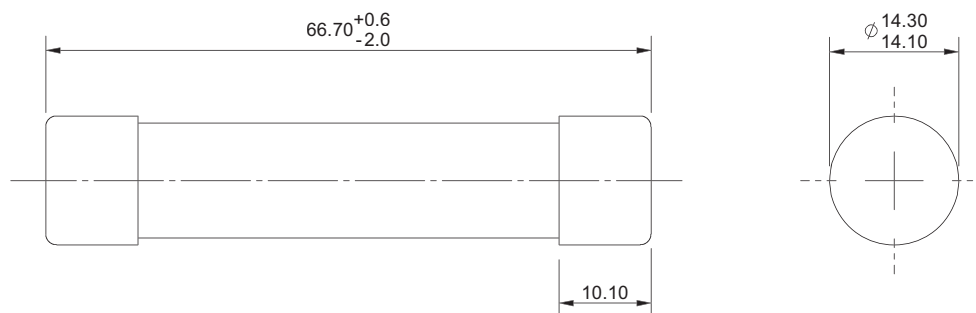

## Dimensions (mm) Cylindrical with 10 mm Fixings PV-\*A14LF10F

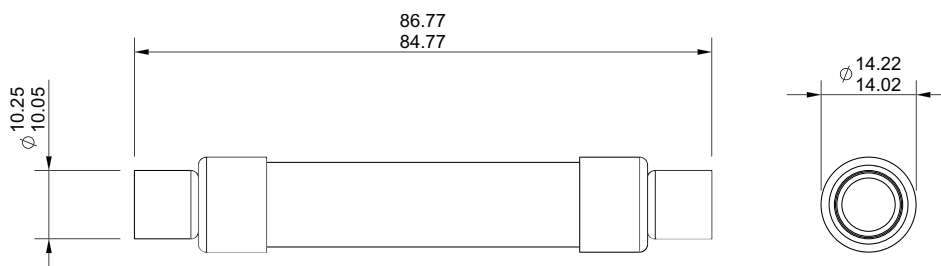

# PV-A14L, 14 x 65 mm photovoltaic fuse links, 3.5 to 32 A, 1300/1500 V d.c.

## Dimensions (mm) Cylindrical with tags PV-\*A14L-T

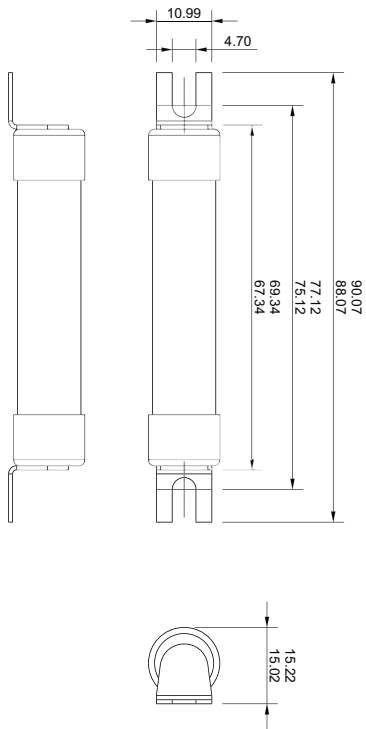

## Time-current curve 2.25 A to 4 A

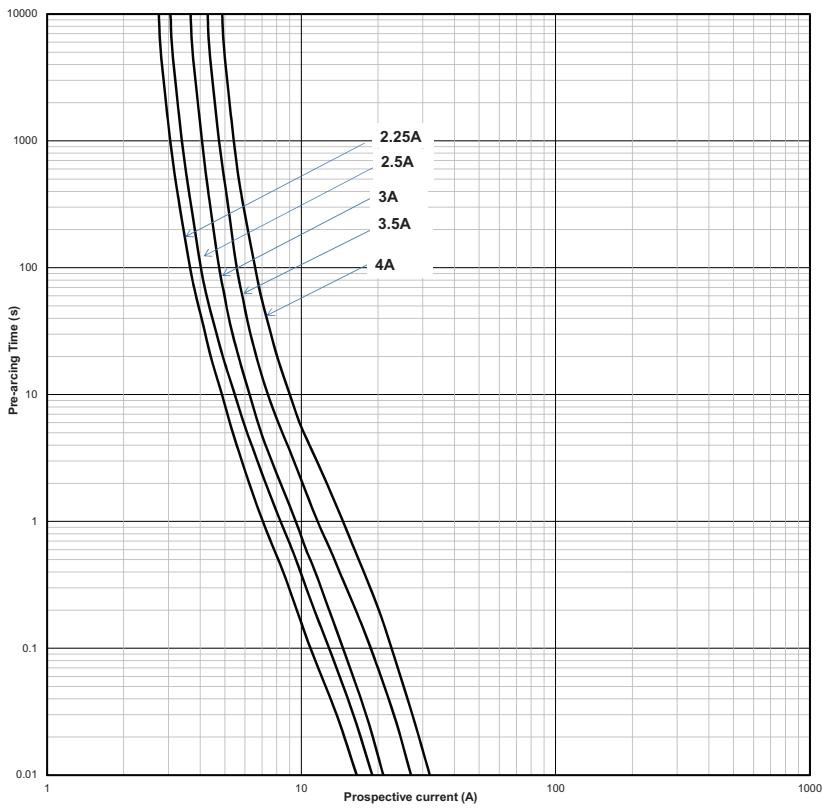

# PV-A14L, 14 x 65 mm photovoltaic fuse links, 3.5 A to 32 A, 1300/1500 V d.c.

## Time-current curve 15 A to 32 A

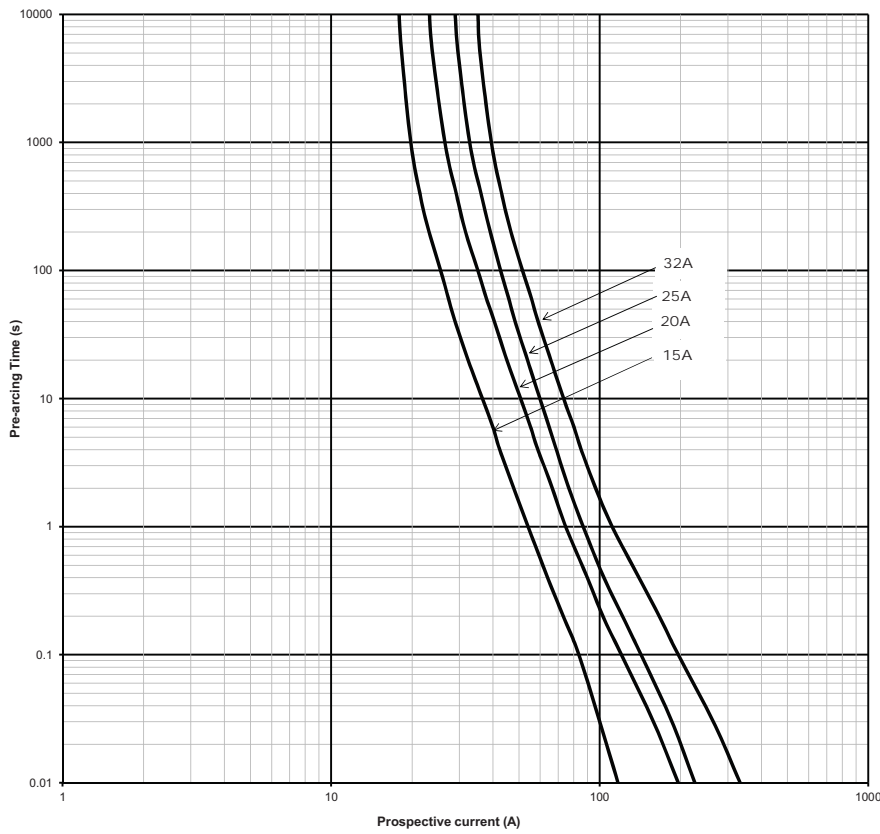

# PV-ANH, NH Photovoltaic fuse links, 32 to 400 A, 1000 V d.c.

## Description

A range of NH size fuse links specifically designed for protecting and isolating photovoltaic array combiners and DC disconnects. These fuse links are capable of interrupting low overcurrents associated with faulted PV systems (reverse current, multi-array fault).

## Catalogue number

PV-(amp rating)ANH(size)

## Technical data

Rated voltage: 1000 V d.c.

Rated current: 32 A to 400 A

Breaking capacity: 50 kA

Operating class: gPV and UL PV fuse links

## Standards / Approvals

IEC 60269-6

UL 2579 (File number E335324)

CSA Listed

RoHS compliant

## Packaging

MOQ: 3

Packaging 100% recyclable

## Recommended microswitches and fuse bases

See table page 35



Microswitch



NH Bases



# PV-ANH, NH Photovoltaic fuse links, 32 to 400 A, 1000 V d.c.

## Technical data

Fuse link body size	Rated voltage	Rated current (Amps)	I <sup>2</sup> t (A <sup>2</sup> Sec)		Watts loss (W)		Catalogue numbers		
			Pre-arcing	Total at 1000 V d.c.	0.8 I <sub>n</sub>	I <sub>n</sub>	Blade without bolt holes	Blade with bolt holes	Blade with bolt holes and lugs
NH1	1000 V d.c. (IEC/UL)	32	80	720	4	8	PV-32ANH1	PV-32ANH1-B	
		40	185	1670	5	9	PV-40ANH1	PV-40ANH1-B	
		50	400	3600	6	11	PV-50ANH1	PV-50ANH1-B	
		63	470	4300	6	12	PV-63ANH1	PV-63ANH1-B	PV-63ANH1-BL
		80	640	5760	8	15	PV-80ANH1	PV-80ANH1-B	PV-80ANH1-BL
		100	1300	11700	8	16	PV-100ANH1	PV-100ANH1-B	PV-100ANH1-BL
		110	2100	18900	9	18.5	PV-110ANH1		
		125	2600	23400	9	17	PV-125ANH1	PV-125ANH1-B	PV-125ANH1-BL
		160	5200	46800	14	27	PV-160ANH1	PV-160ANH1-B	PV-160ANH1-BL
		175	8300	74700	15	29	PV-175ANH1		
		200	10200	82000	13	25	PV-200ANH1	PV-200ANH1-B	PV-200ANH1-BL
NH2	1000 V d.c. (IEC/UL)	160	4600	37000	14	28	PV-160ANH2	PV-160ANH2-B	PV-160ANH2-BL
		200	9500	76000	16	32	PV-200ANH2	PV-200ANH2-B	PV-200ANH2-BL
		250	17000	136000	19	38	PV-250ANH2	PV-250ANH2-B	PV-250ANH2-BL
NH3	1000 V d.c. (IEC/UL)	300	32000	260000	24	40	PV-300ANH3		
		315	32000	260000	26	44	PV-315ANH3	PV-315ANH3-B	PV-315ANH3-BL
		350	44500	370000	27	45	PV-350ANH3		
		355	44500	370000	28	46	PV-355ANH3		
		355	38000	310000	29	48		PV-355ANH3-B	PV-355ANH3-BL
		400	67500	550000	30	50	PV-400ANH3		
		400	61000	490000	32	50		PV-400ANH3-B	PV-400ANH3-BL

## Compatible NH fuse bases and microswitches

Fuse link body size	Rated voltage	Rated current (Amps)	Catalogue numbers			Compatible NH fuse bases	Compatible microswitches
			Blade without bolt holes	Blade with bolt holes	Blade with bolt holes and lugs		
NH1	1000 V d.c. (IEC/UL)	32	PV-32ANH1	PV-32ANH1-B		SD1-D-PV	170H0236 and 170H0238
		40	PV-40ANH1	PV-40ANH1-B		SD1-D-PV	170H0236 and 170H0238
		50	PV-50ANH1	PV-50ANH1-B		SD1-D-PV	170H0236 and 170H0238
		63	PV-63ANH1	PV-63ANH1-B	PV-63ANH1-BL	SD1-D-PV	170H0236 and 170H0238
		80	PV-80ANH1	PV-80ANH1-B	PV-80ANH1-BL	SD1-D-PV	170H0236 and 170H0238
		100	PV-100ANH1	PV-100ANH1-B	PV-100ANH1-BL	SD1-D-PV	170H0236 and 170H0238
		110	PV-110ANH1			SD1-D-PV	170H0236 and 170H0238
		125	PV-125ANH1	PV-125ANH1-B	PV-125ANH1-BL	SD1-D-PV	170H0236 and 170H0238
		160	PV-160ANH1	PV-160ANH1-B	PV-160ANH1-BL	SD1-D-PV	170H0236 and 170H0238
		175	PV-175ANH1			SD1-D-PV	170H0236 and 170H0238
		200	PV-200ANH1	PV-200ANH1-B	PV-200ANH1-BL	SD1-D-PV	170H0236 and 170H0238
NH2	1000 V d.c. (IEC/UL)	160	PV-160ANH2	PV-160ANH2-B	PV-160ANH2-BL	SD2-D-PV	170H0236 and 170H0238
		200	PV-200ANH2	PV-200ANH2-B	PV-200ANH2-BL	SD2-D-PV	170H0236 and 170H0238
		250	PV-250ANH2	PV-250ANH2-B	PV-250ANH2-BL	SD2-D-PV	170H0236 and 170H0238
NH3	1000 V d.c. (IEC/UL)	300	PV-300ANH3			SD3-D-PV	170H0236 and 170H0238
		315	PV-315ANH3	PV-315ANH3-B	PV-315ANH3-BL	SD3-D-PV	170H0236 and 170H0238
		350	PV-350ANH3			SD3-D-PV	170H0236 and 170H0238
		355	PV-355ANH3			SD3-D-PV	170H0236 and 170H0238
		355		PV-355ANH3-B	PV-355ANH3-BL	SD3-D-PV	170H0236 and 170H0238
		400	PV-400ANH3			SD3-D-PV	170H0236 and 170H0238
		400		PV-400ANH3-B	PV-400ANH3-BL	SD3-D-PV	170H0236 and 170H0238

# PV-ANH, NH Photovoltaic fuse links, 32 to 400 A, 1000 V d.c.

## Dimensions (mm) NH1 Blade without bolt holes

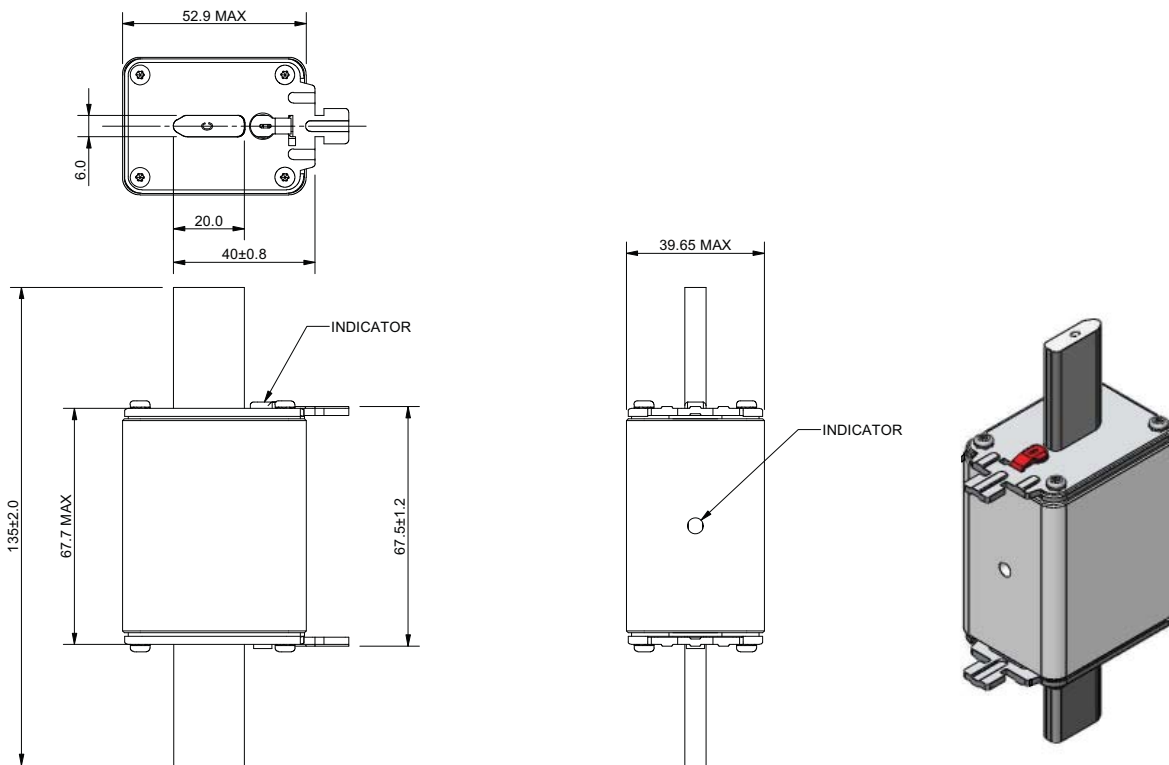

## Dimensions (mm) NH2 Blade without bolt holes

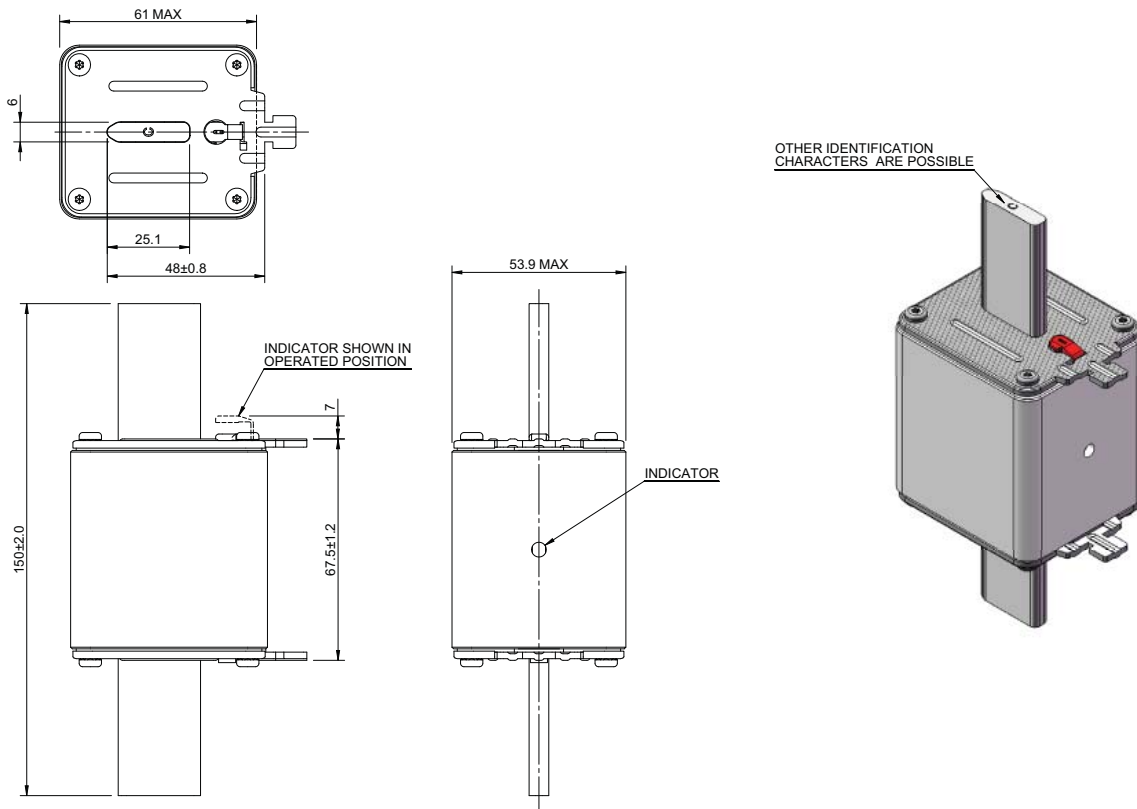

# PV-ANH, NH Photovoltaic fuse links, 32 to 400 A, 1000 V d.c.

## Dimensions (mm) NH3 Blade without bolt holes

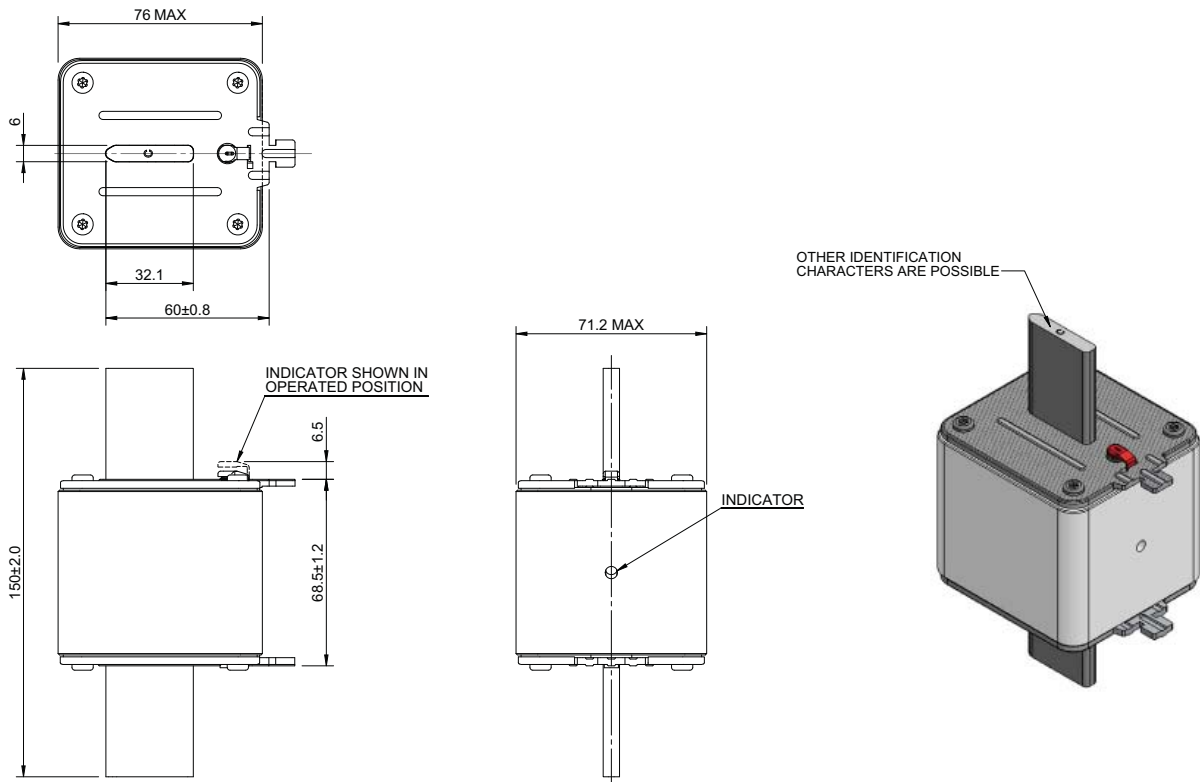

## Dimensions (mm) NH1 Blade with bolt holes

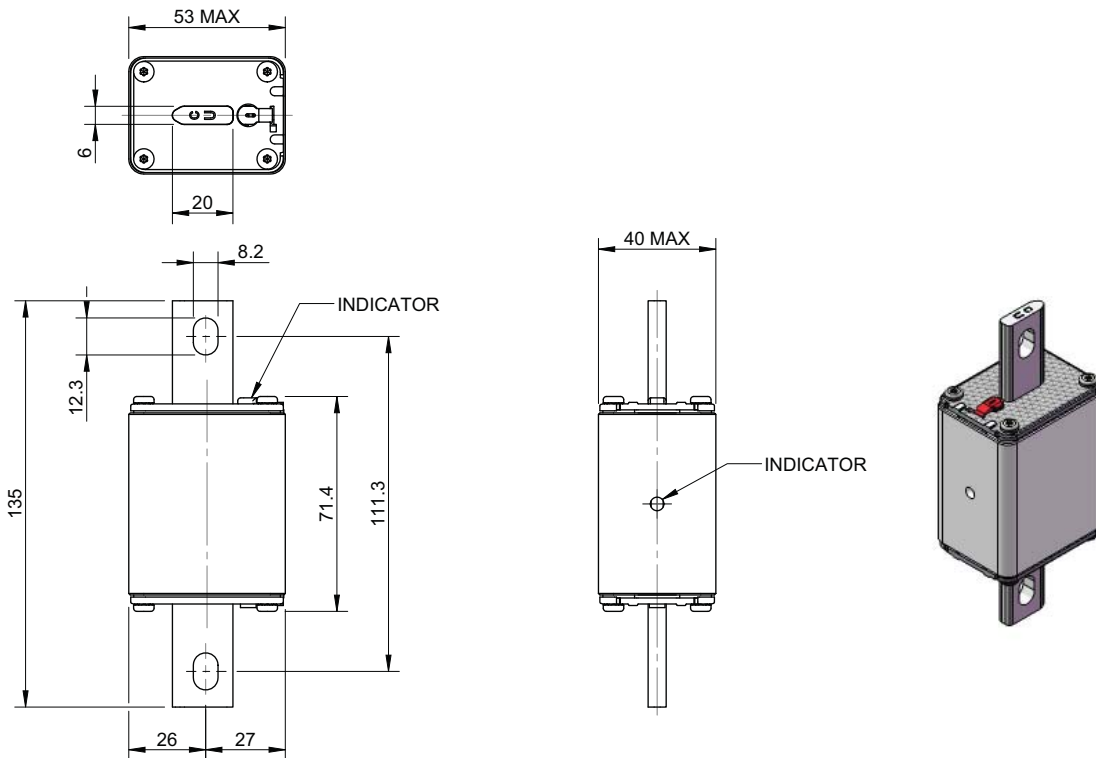

# PV-ANH, NH Photovoltaic fuse links, 32 to 400 A, 1000 V d.c.

## Dimensions (mm) NH2 Blade with bolt holes

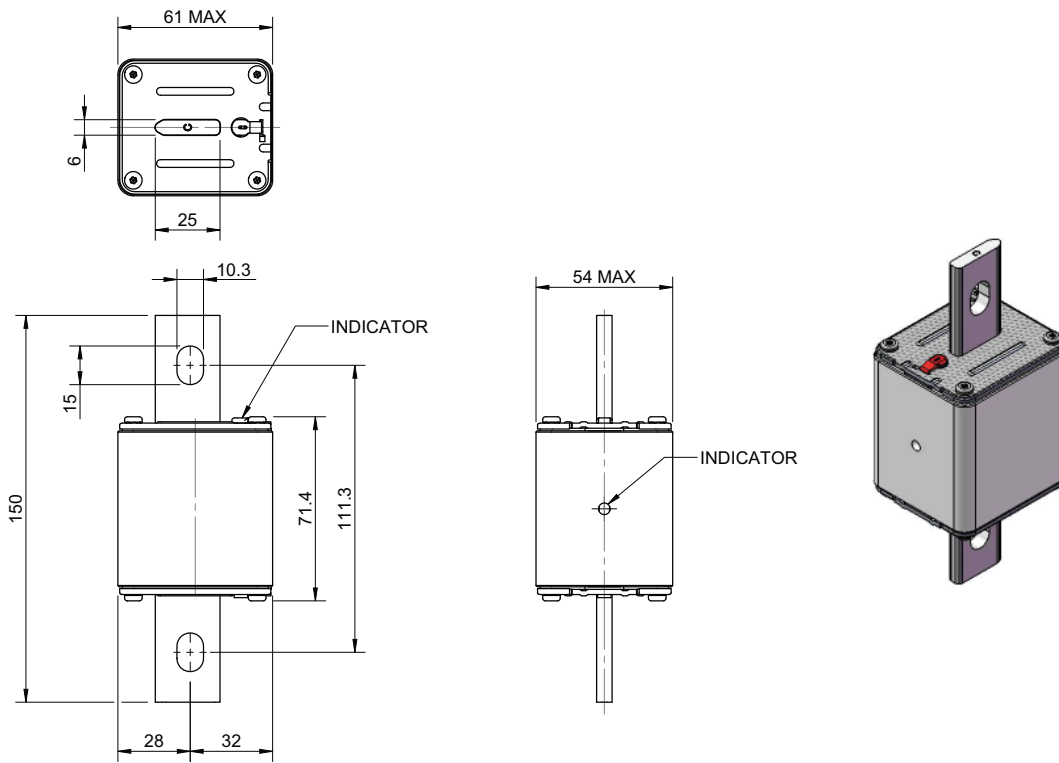

## Dimensions (mm) NH3 Blade with bolt holes

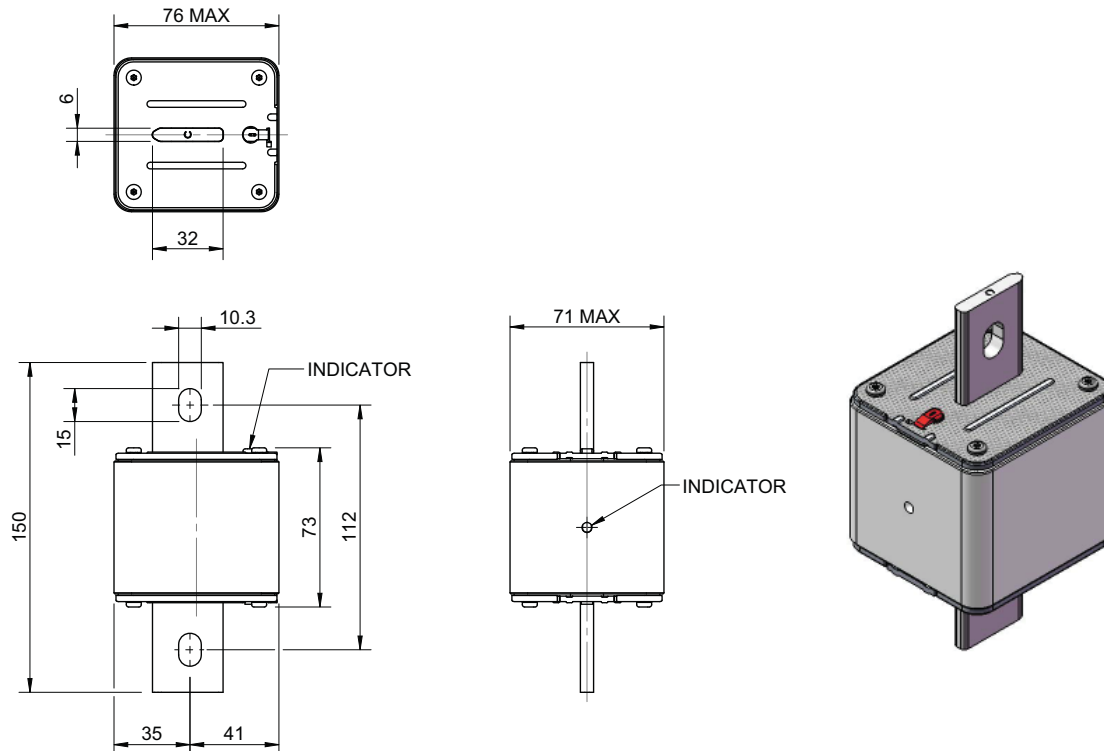

# PV-ANH, NH Photovoltaic fuse links, 32 to 400 A, 1000 V d.c.

## Dimensions (mm) NH1 Blade with bolt holes and lugs

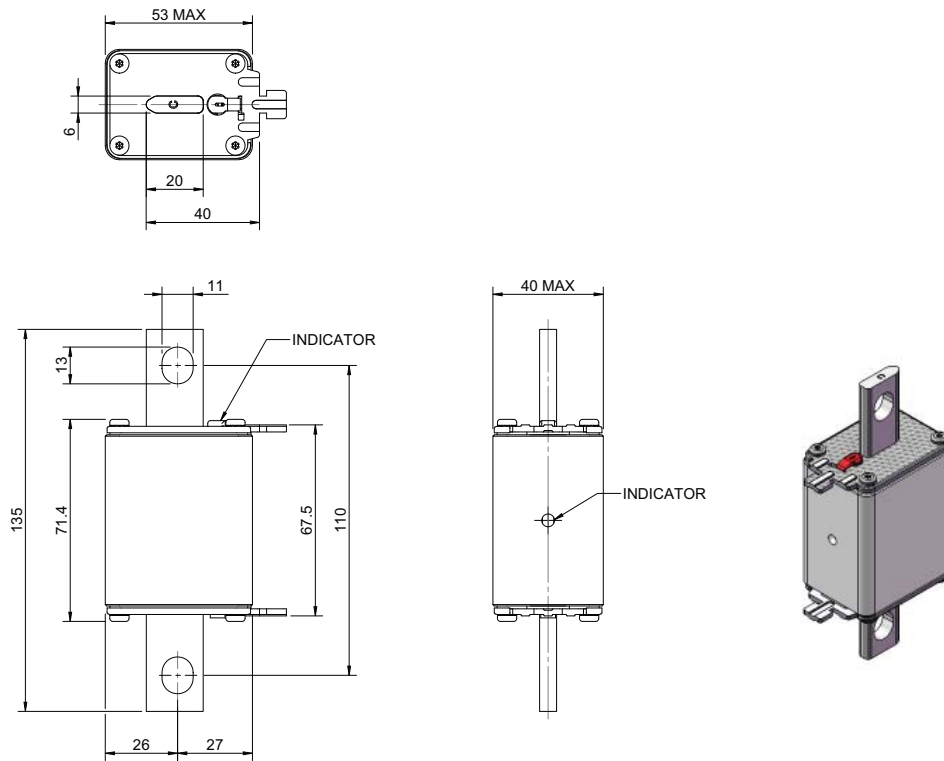

## Dimensions (mm) NH2 Blade with bolt holes and lugs

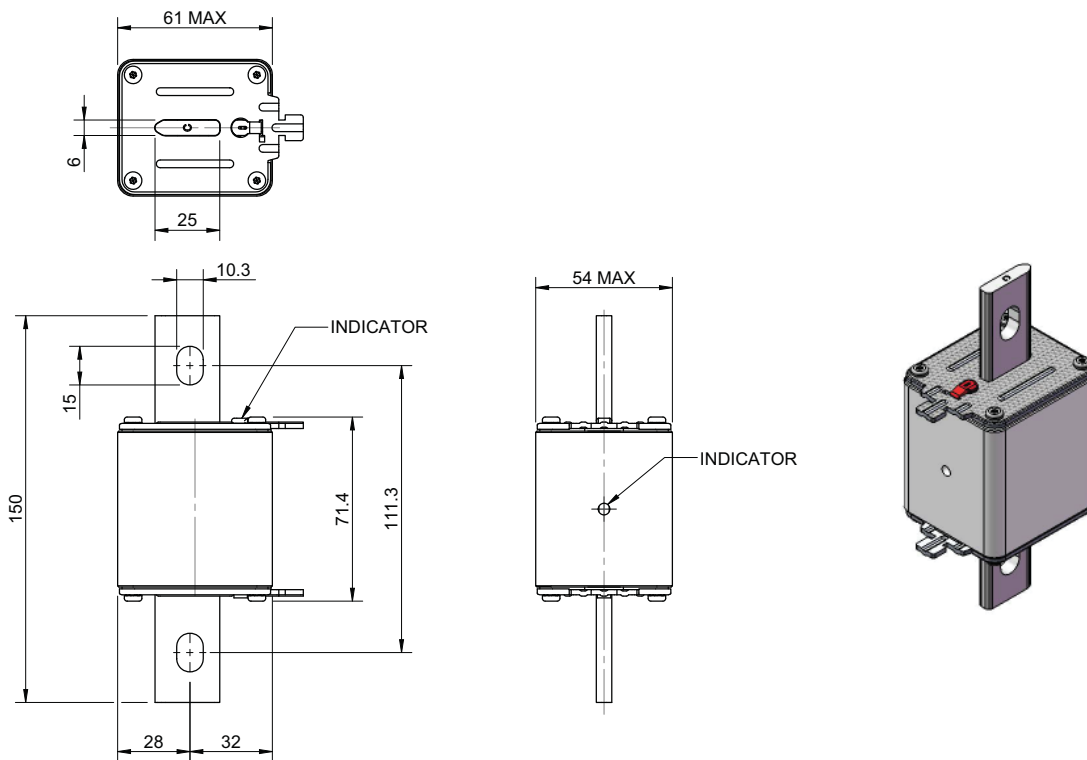

# PV-ANH, NH Photovoltaic fuse links, 32 to 400 A, 1000 V d.c.

## Dimensions (mm) NH3 Blade with bolt holes and lugs

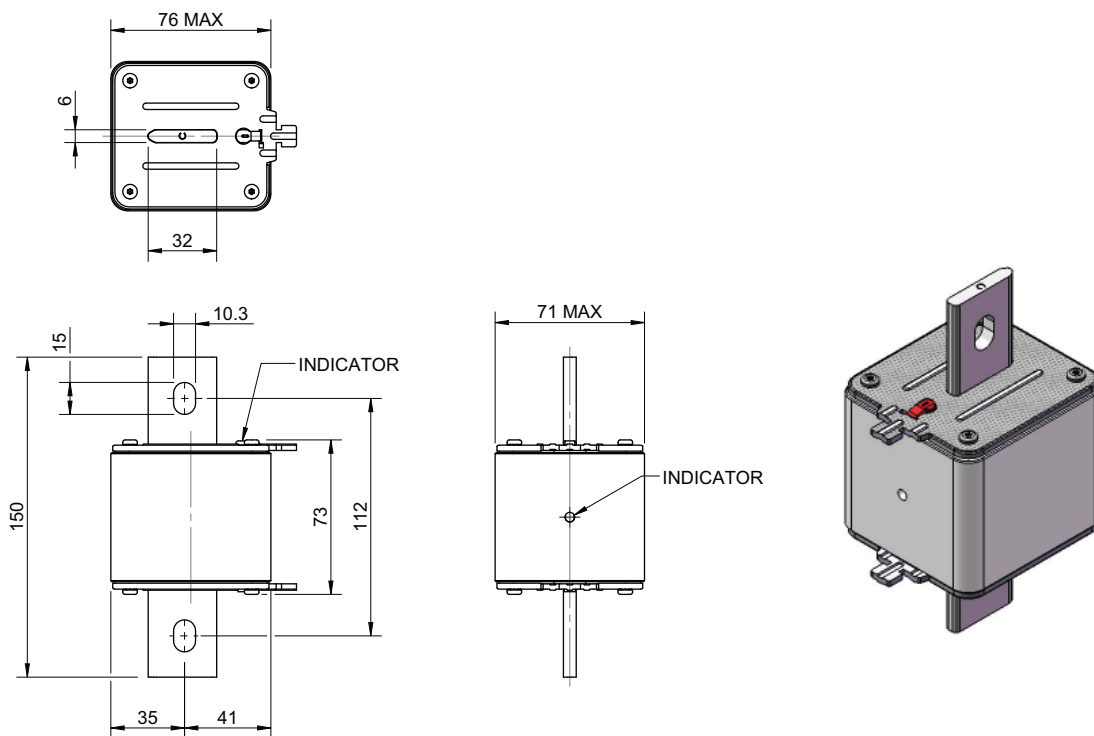

## Time-current curve size 1 - 32 A to 200 A

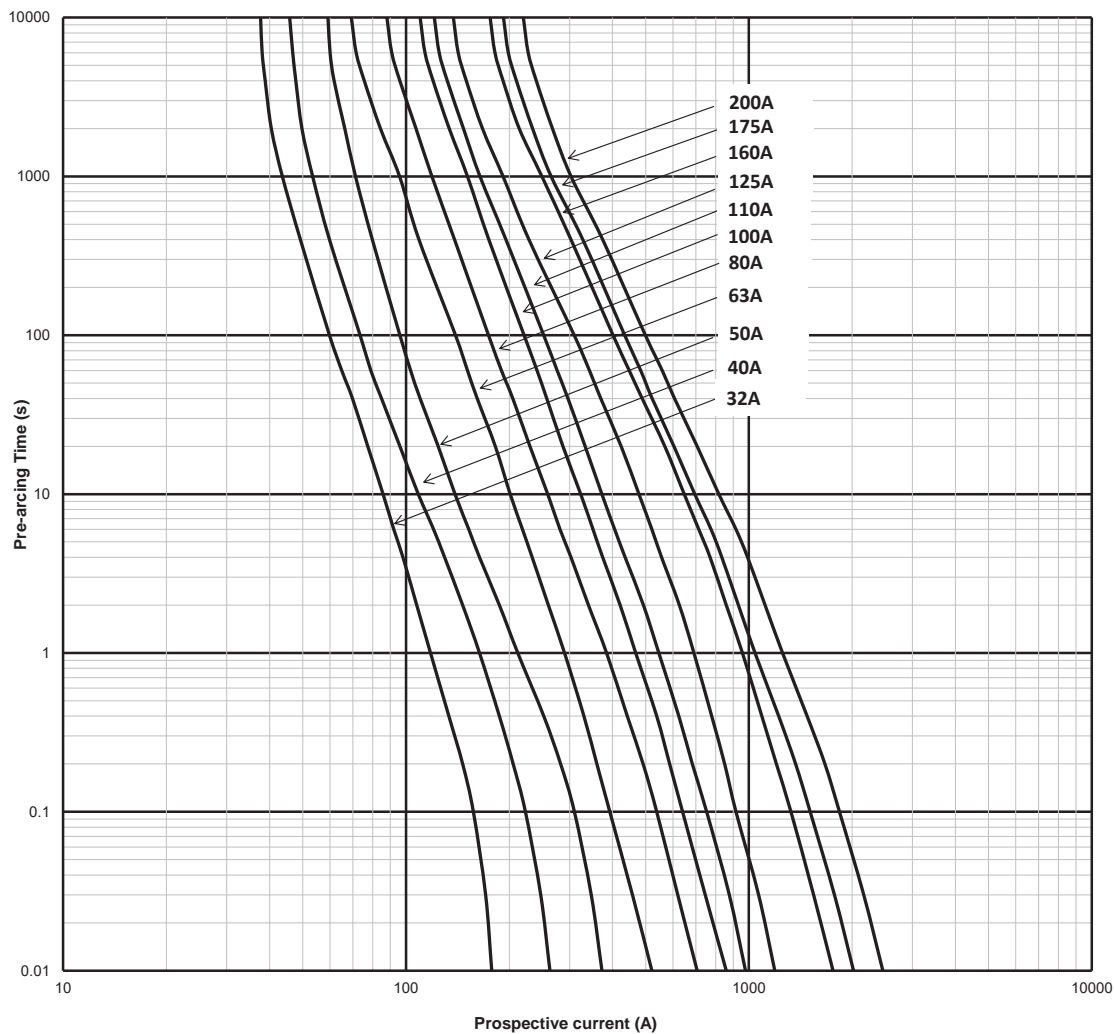

# PV-ANH, NH Photovoltaic fuse links, 32 to 400 A, 1000 V d.c.

Time-current curve size 2 - 160 A to 250 A

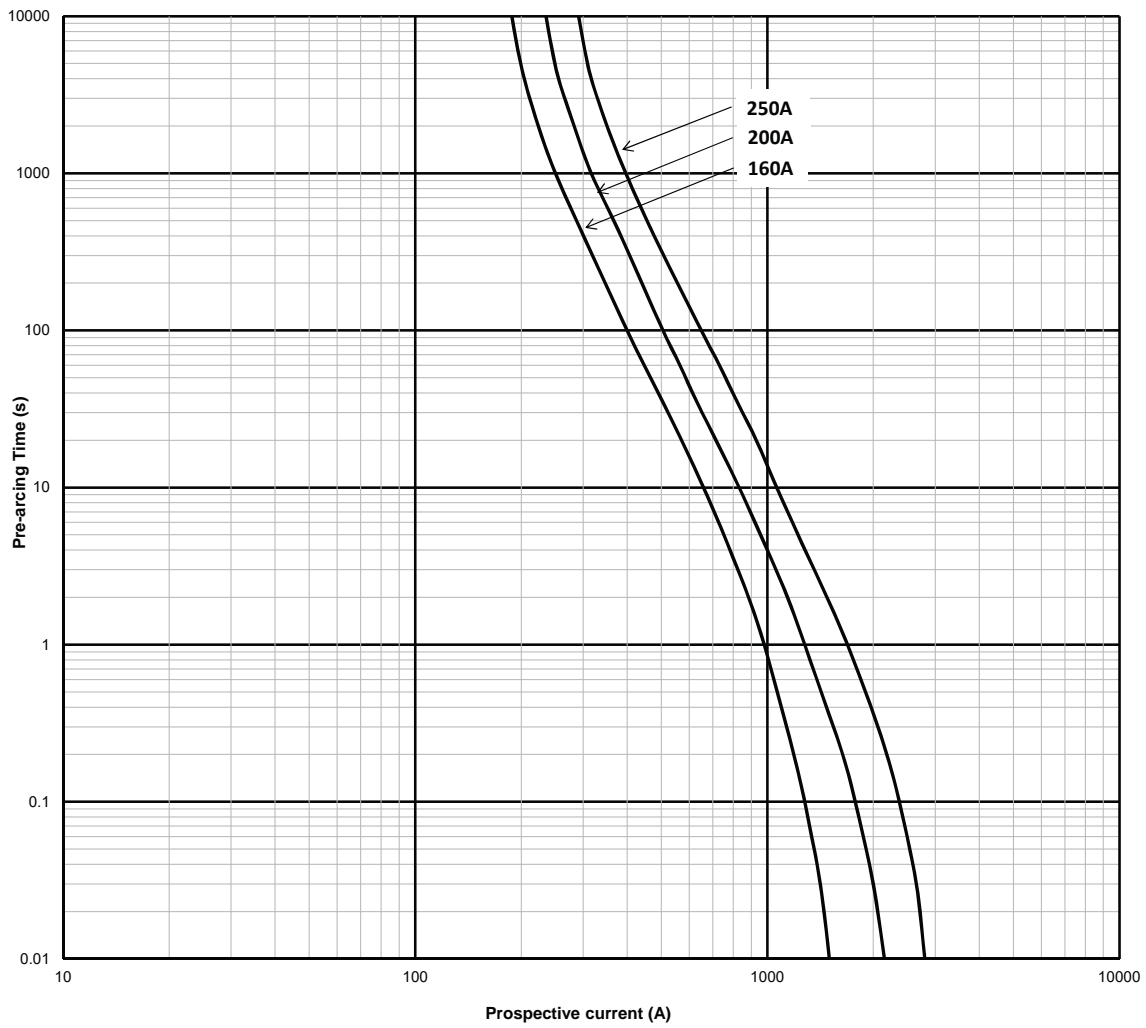

# PV-ANH, NH Photovoltaic fuse links, 32 to 400 A, 1000 V d.c.

Time-current curve size 3 - 300 A to 400 A

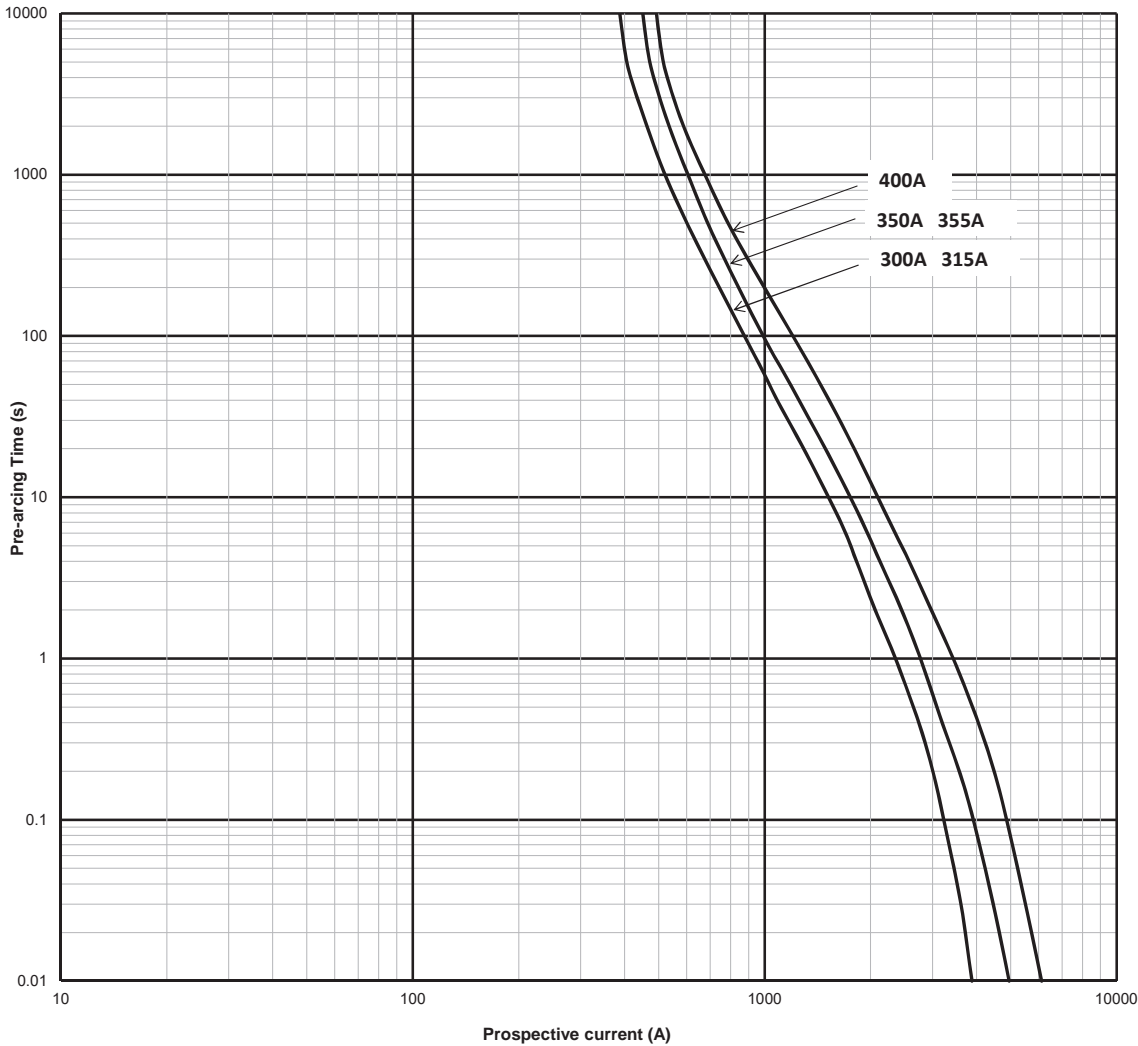

Temperature derating curve - sizes 1 to 3

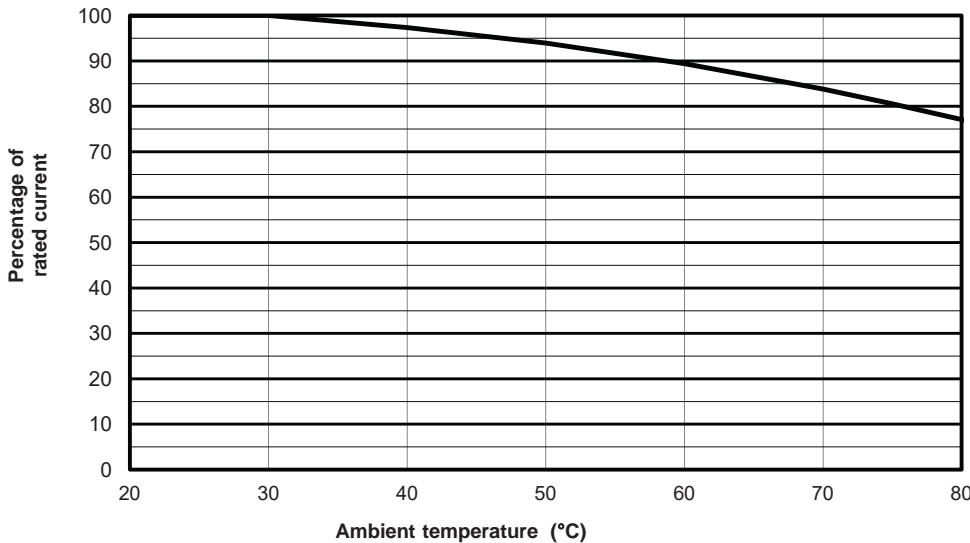

# SD-D-PV, NH Bases, 250 to 630 A, 1500 V d.c. (IEC), 1000 V d.c. (UL/CSA)

## Description

Sizes 1 to 3 NH Fuse bases specifically designed for use with Bussmann series range of NH PV (Photovoltaic) fuse links.

## Technical data

Rated voltage:

- 1500 V d.c. (IEC)
- 1000 V d.c. (UL/CSA)

Rated current:

- 250 A (SD1)
- 400 A (SD2)
- 630 A (SD3)

Fuse base sizes: 1 to 3

Withstand: 50 kA

Power acceptance

- SD1: 32 W
- SD2: 45 W
- SD3: 60 W



## Standards / Agency information

IEC 60269-1

UL Listed - UL File #E348242,

CSA file #47235

## Accessories:

Microswitches - 170H0236, 170H0238 or BVL50

BVL50 IP20 Finger-Safe Protection Kit - TD1-IP20, TD2-IP20, TD3-IP20.

Fuse extraction handle

Shroud kits

## Dimensions (mm) 1-pole with phase barriers

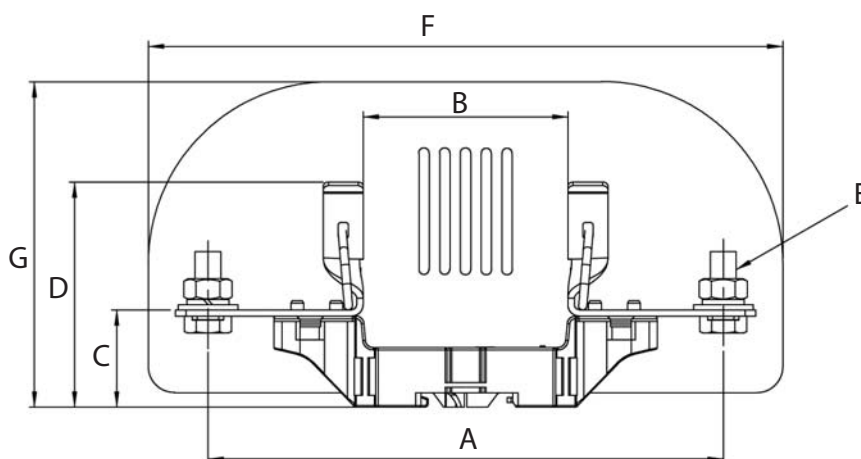

Catalogue numbers	Poles/Type	A	B	C	D	E	F	G
SD1-D-PV	1-pole	175	79	37	78	M10x25	245	125.5
SD2-D-PV	1 pole	199	79	37.5	86	M10x25	245	125.5
SD3-D-PV	1-pole	209	82	37.5	88	M12x30	260	137.5

Data sheet: 720149

# SD-D-PV, NH Bases, 250 to 630 A, 1500 V d.c. (IEC), 1000 V d.c. (UL/CSA)

## Dimensions (mm) 1-pole without phase barriers

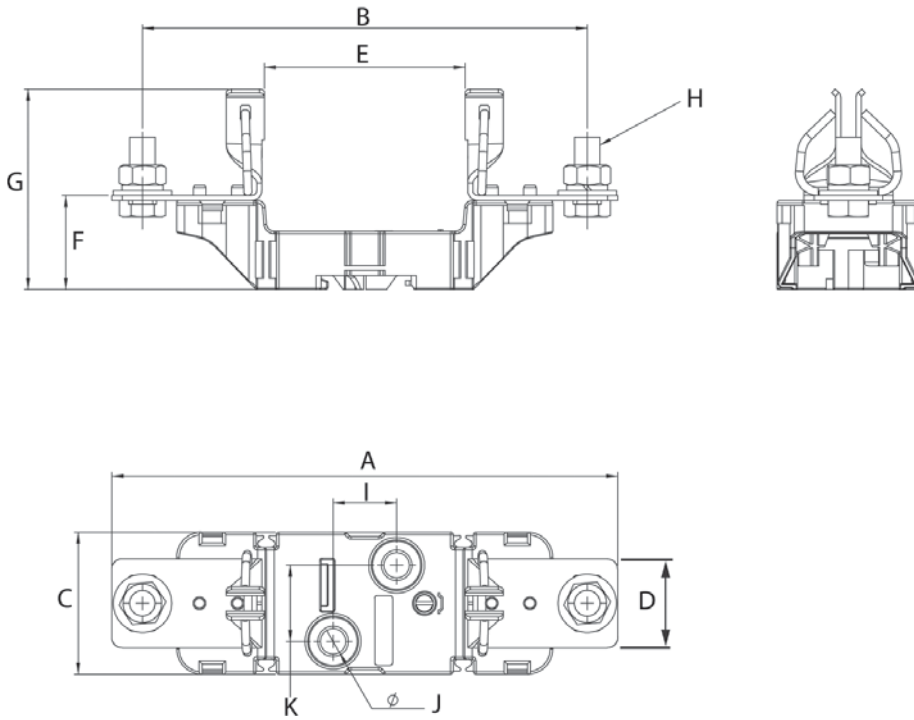

Catalogue numbers	Poles	A	B	C	D	E	F	G	H	I	J	K
SD1-D-PV	1-pole	199	175	56	35	79	37	78	M10x25	25	10	30
SD2-D-PV	1 pole	224	199	56	35	79	37.5	86	M10x25	25	10	30
SD3-D-PV	1-pole	239	209	56	36	82	37.5	88	M12x30	25	10	30

# PV-AF Series, PV Flush end, 160 to 400 A, 1000 V d.c.

## Description

A range of flush end package fuse links specifically designed for protecting and isolating photovoltaic array combiners and disconnects. These fuse links are capable of interrupting low overcurrents associated with faulted PV systems (reverse current, multi-array fault).

## Catalogue number

PV-(amp rating)AF2 - size 2

PV-(amp rating)AF3 - size 3

## Class of operation

gPV

## Technical data

Rated voltage: 1000 V d.c. (IEC and UL)

Rated current: 160 A to 400 A

Breaking capacity: 50 kA

Operating class: gPV and UL PV fuse links

## Optional microswitches

170H0069

## Standards / Approvals

Tested to IEC 60269-6

UL 2579 (file number E335324)

CSA

RoHS compliant

## Packaging

MOQ: 2 for size 2 (PV-xAF2), 1 for size 3 (PV-xAF3)

Packaging 100% recyclable.



## Technical data

Fuse link type	Fuse link body size	Rated voltage	Rated current (Amps)	I <sup>2</sup> t (A <sup>2</sup> Sec)		Watts loss (W)		Catalogue numbers
				Pre-arcing	Total at 1000 V d.c.	0.8 I <sub>n</sub>	I <sub>n</sub>	
Flush end	2	1000 V d.c.(IEC/UL)	160	4600	37,000	15	30	PV-160AF2
			200	9500	76,000	17	34	PV-200AF2
			250	17,000	136,000	19	38	PV-250AF2
	3	1000 V d.c.(IEC/UL)	315	27,000	240,000	30	49	PV-315AF3
			355	37,000	350,000	31	51	PV-355AF3
			400	61,500	550,000	32	52	PV-400AF3

# PV-AF, PV Flush end, 160 to 400 A, 1000 V d.c.

## Dimensions (mm) - size 2

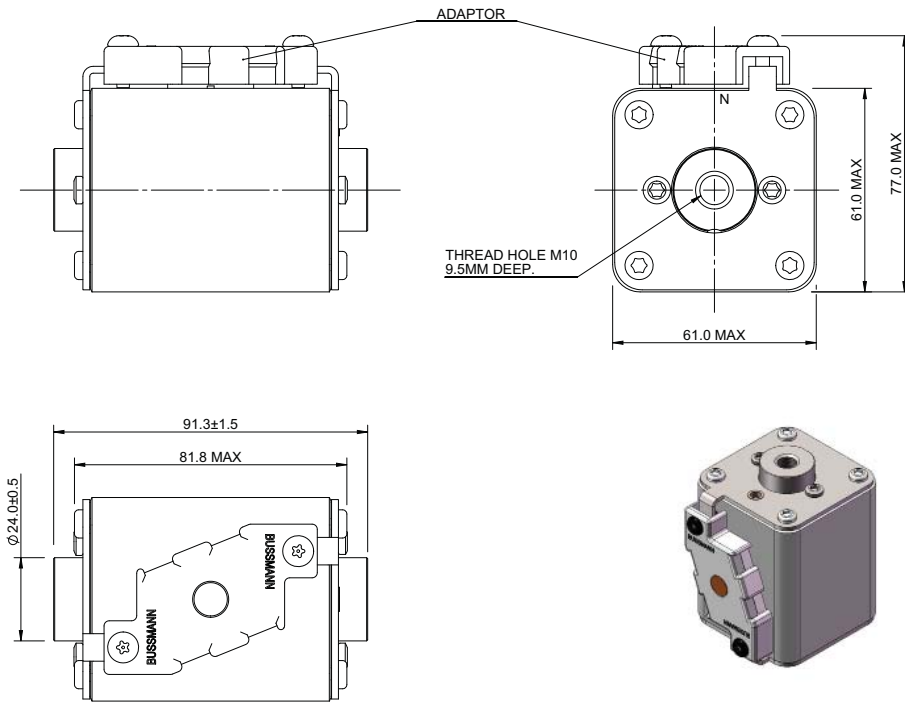

## Dimensions (mm) - size 3

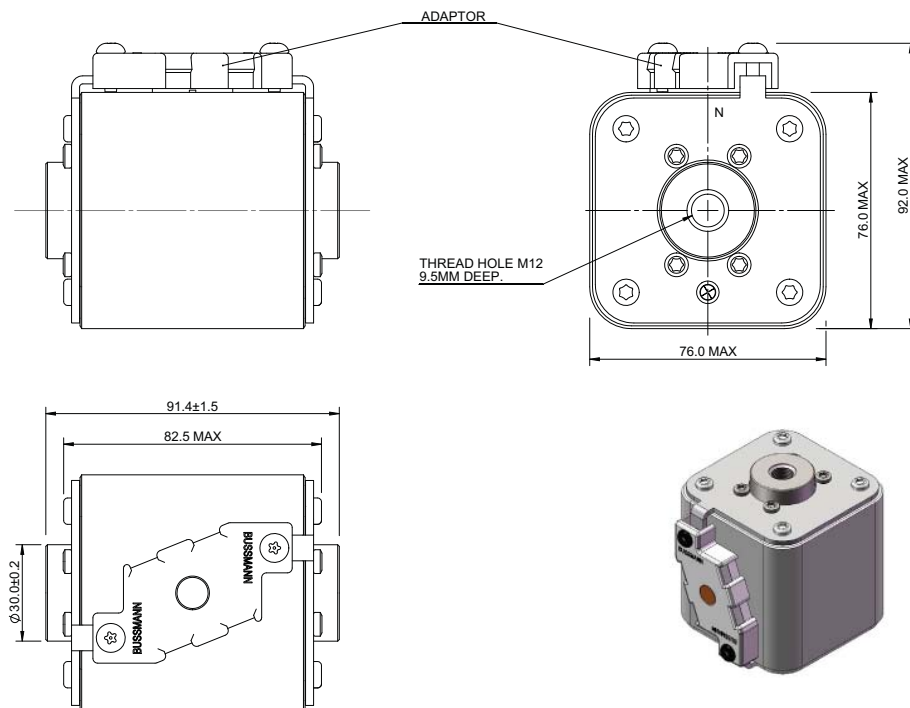

# PV-AF Series, PV Flush end, 160 to 400 A, 1000 V d.c.

## Time-current curve size 2 - 160 A to 250 A

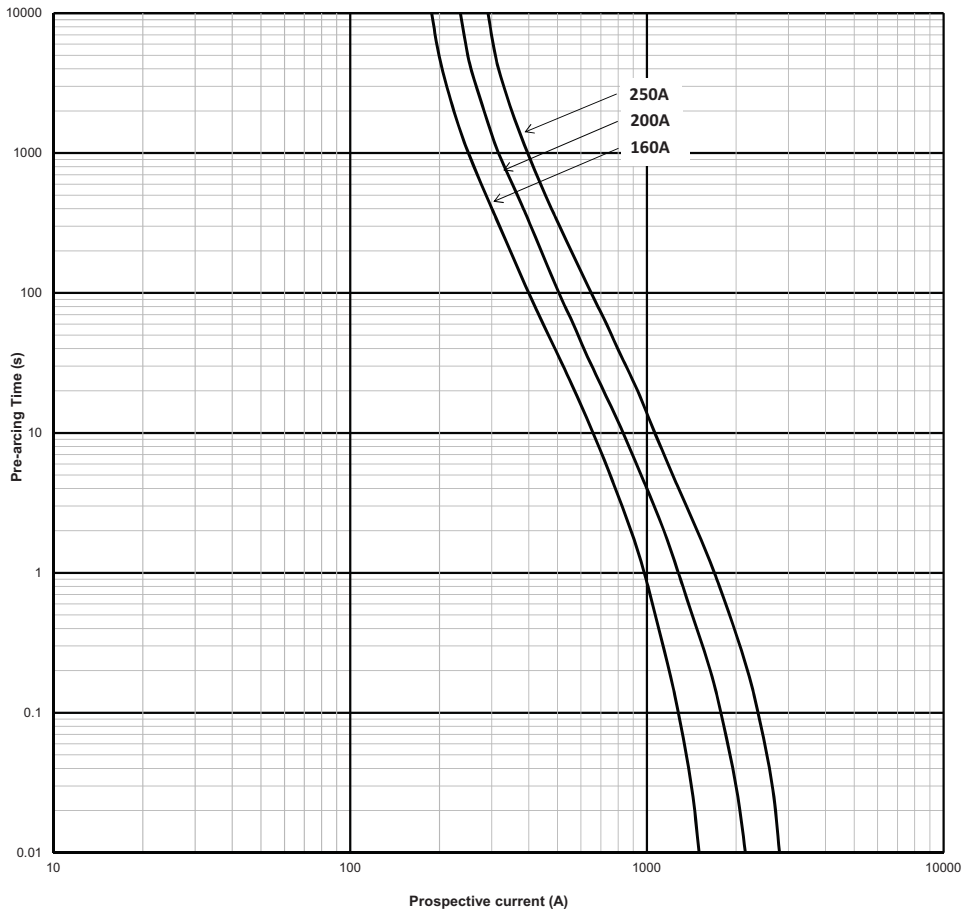

## Time-current curve size 3 - 315 A to 400 A

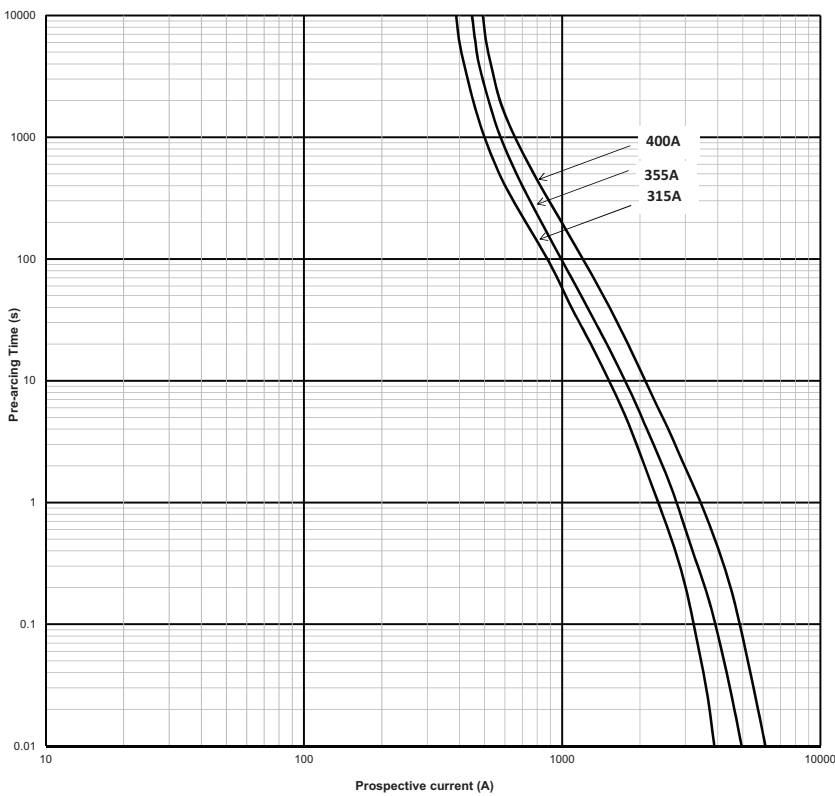

# PV-XL, XL Style photovoltaic fuse links, 50 to 600 A, 1000/1500 V d.c.

## Description

A range of XL package fuse links specifically designed for protecting and isolating photovoltaic array combiners and disconnects. These fuse links are capable of interrupting low overcurrents associated with faulted PV systems (reverse current, multi-array fault).

## Catalogue number

PV-(amp rating)A-(size)XL (1000 V d.c. Bladed)

PV-(amp rating)A-(size)XL-B (1000 V d.c. Bolted)

PV-(amp rating)A-2XL-3B<sup>1</sup> (1000 V d.c. Bolted)

PV-(amp rating)A-(size)XL-15 (1500 V d.c. Bladed)

PV-(amp rating)A-(size)XL-B-15 (1500 V d.c. Bolted)

PV-(amp rating)A-2XL-3B-15<sup>1</sup> (1500 V d.c. Bolted)

## Technical data

Rated voltage:

- 1000 V d.c. (IEC and UL 63 to 600 A)
- 1200 V d.c. (IEC and UL 160 A)
- 1500 V d.c. (IEC and UL 50 to 400 A)

Rated current: 50 A to 600 A

Breaking capacity:

- Size 01 and 3: 50 kA at 1000 V d.c., 30 kA at 1500 V d.c.
- Size 1 and 2: 33 kA at 1000 V d.c., 30 kA at 1500 V d.c.
- Size 3L: 100 kA at 1500 V d.c.6ms

Operating class: gPV and UL PV fuse links

## Fuse size

01XL, 1XL, 2XL and 3L

## Standards / Approvals

IEC 60269-6,

UL 2579 (File number E335324)

RoHS compliant

## Packaging

MOQ: 1

Packaging 100% recyclable



## Recommended single-pole fuse bases and microswitches

See tables pages 50 to 52



170H0236



170H0069



SD\_XL-S

<sup>1</sup> PV-\*A-2XL-3B and PV-\*A-2XL-3B-15 have revised bolting patterns, which are identical to size 3L bolting pattern. This allows utilisation of both size 2XL and size 3L fuse links without changing the dimensional layout of the inverter, combiners and disconnects.

Data sheet: 10201

# PV-XL, XL Style photovoltaic fuse links, 50 to 600 A, 1000/1500 V d.c.

## Technical Data - 1000 V d.c.

Fuse link body size	Rated voltage	Rated current (Amps)	Breaking capacity (kA)	I <sup>2</sup> t (A <sup>2</sup> Sec)		Watts loss (W)		Catalogue numbers	
				Pre-arcing	Total at 1000 V d.c.	0.7 I <sub>n</sub>	I <sub>n</sub>	Bladed version	Bolted version
01	1000 V d.c.	63	50	260	1900	10	24	PV-63A-01XL	PV-63A-01XL-B
		80	50	490	3600	12	29	PV-80A-01XL	PV-80A-01XL-B
		100	50	870	6300	13	32	PV-100A-01XL	PV-100A-01XL-B
		125	50	1930	13,900	16	40	PV-125A-01XL	PV-125A-01XL-B
		160	50	3900	28,100	18	44	PV-160A-01XL	PV-160A-01XL-B
2	1000 V d.c.	160	33	2780	21,000	18	44	PV-160A-2XL	PV-160A-2XL-B
		200	33	4950	37,000	20	50	PV-200A-2XL	PV-200A-2XL-B
		250	33	9450	70,000	24	60	PV-250A-2XL	PV-250A-2XL-B
		315	33	16,600	123,000	26	66	PV-315A-2XL	PV-315A-2XL-B
		355	33	26,000	192,000	27	68	PV-355A-2XL	PV-355A-2XL-B
		160	33	2780	21,000	18	44		PV-160A-2XL-3B <sup>1</sup>
		200	33	4950	37,000	20	50		PV-200A-2XL-3B <sup>1</sup>
		250	33	9450	70,000	24	60		PV-250A-2XL-3B <sup>1</sup>
		315	33	16,600	123,000	26	66		PV-315A-2XL-3B <sup>1</sup>
		355	33	26,000	192,000	27	68		PV-355A-2XL-3B <sup>1</sup>
3	1000 V d.c.	350	50	31,000	161,200	26	65	PV-350A-3L	PV-350A-3L-B
		400	50	44,500	231,400	33	82	PV-400A-3L	PV-400A-3L-B
		500	50	85,000	442,000	34	85	PV-500A-3L	PV-500A-3L-B
		600	50	137,000	712,400	43	108	PV-600A-3L	PV-600A-3L-B

## Technical Data - 1500 V d.c.

Fuse link body size	Rated voltage	Rated current (Amps)	Breaking capacity (kA)	I <sup>2</sup> t (A <sup>2</sup> Sec)		Watts loss (W)		Catalogue numbers			
				Pre-arcing	Total at 1500 V <sup>1</sup>	0.7 I <sub>n</sub>	I <sub>n</sub>	Bladed with top indicator	Bladed without top indicator	Bolted version with side indicator	Bolted without side indicator
01	1500 V d.c.	50	30	175	1000	10	25	PV-50A-01XL-15		PV-50A-01XL-B-15	
		63	30	362	2250	10	26	PV-63A-01XL-15		PV-63A-01XL-B-15	
		80	30	565	3300	14	35	PV-80A-01XL-15		PV-80A-01XL-B-15	
		100	30	1100	6600	16	40	PV-100A-01XL-15		PV-100A-01XL-B-15	
		125	30	2200	10,500	18	44	PV-125A-01XL-15		PV-125A-01XL-B-15	
1	1500 V d.c.	100	30	1250	6000	24	43	PV-100A-1XL-15		PV-100A-1XL-B-15	
		125	30	1950	9360	25	52	PV-125A-1XL-15		PV-125A-1XL-B-15	
		160	30	4200	20,160	26	54	PV-160A-1XL-15		PV-160A-1XL-B-15	
		200	30	9400	45,120	31	60	PV-200A-1XL-15		PV-200A-1XL-B-15	
2	1500 V d.c.	125	30	2200	15,000	18	44	PV-125A-2XL-15	PV-125A-2XL-U-15	PV-125A-2XL-B-15	PV-125A-2XL-BU-15
		160	30	5000	32,000	19	48	PV-160A-2XL-15	PV-160A-2XL-U-15	PV-160A-2XL-B-15	PV-160A-2XL-BU-15
		200	30	8800	51,000	23	57	PV-200A-2XL-15	PV-200A-2XL-U-15	PV-200A-2XL-B-15	PV-200A-2XL-BU-15
		250	30	16,600	85,000	28	70	PV-250A-2XL-15	PV-250A-2XL-U-15	PV-250A-2XL-B-15	PV-250A-2XL-BU-15
		125	30	2200	15,000	18	44			PV-125A-2XL-3B-15 <sup>1</sup>	PV-125A-2XL-3BU-15 <sup>1</sup>
		160	30	5000	32,000	19	48			PV-160A-2XL-3B-15 <sup>1</sup>	PV-160A-2XL-3BU-15 <sup>1</sup>
		200	30	8800	51,000	23	57			PV-200A-2XL-3B-15 <sup>1</sup>	PV-200A-2XL-3BU-15 <sup>1</sup>
		250	30	16,600	85,000	28	70			PV-250A-2XL-3B-15 <sup>1</sup>	PV-250A-2XL-3BU-15 <sup>1</sup>
3	1500 V d.c.	250	100	74,000	263,000	20	49	PV-250A-3L-15	PV-250A-3L-U-15	PV-250A-3L-B-15	PV-250A-3L-BU-15
		315	100	150,000	533,000	21	52	PV-315A-3L-15	PV-315A-3L-U-15	PV-315A-3L-B-15	PV-315A-3L-BU-15
		350	100	195,000	693,000	24	59	PV-350A-3L-15	PV-350A-3L-U-15	PV-350A-3L-B-15	PV-350A-3L-BU-15
		355	100	195,000	693,000	24	59	PV-355A-3L-15	PV-355A-3L-U-15	PV-355A-3L-B-15	PV-355A-3L-BU-15
		400	100	296,000	1,060,000	24	61	PV-400A-3L-15	PV-400A-3L-U-15	PV-400A-3L-B-15	PV-400A-3L-BU-15
		450	100	412,000	1,470,000	27	67	PV-450A-3L-15	PV-450A-3L-U-15	PV-450A-3L-B-15	PV-450A-3L-BU-15
		500	100	532,000	1,890,000	29	73	PV-500A-3L-15	PV-500A-3L-U-15	PV-500A-3L-B-15	PV-500A-3L-BU-15

<sup>1</sup> PV-\*A-2XL-3B and PV-\*A-2XL-3B-15 have revised bolting patterns, which are identical to size 3L bolting pattern. This allows utilisation of both size 2XL and size 3L fuse links without changing the dimensional layout of the inverter, combiners and disconnects.

# PV-XL, XL Style photovoltaic fuse links, 50 to 600 A, 1000/1500 V d.c.

## Compatible fuse bases and microswitches - 1000 V d.c.

Fuse link body size	Rated voltage	Rated current (Amps)	Fuse type	Catalogue numbers	Compatible Fuse bases	Compatible microswitches
01	1000 V d.c.	63		PV-63A-01XL	SD1XL-S-PV	170H0236/170H0238
		80		PV-80A-01XL	SD1XL-S-PV	170H0236/170H0238
		100		PV-100A-01XL	SD1XL-S-PV	170H0236/170H0238
		125		PV-125A-01XL	SD1XL-S-PV	170H0236/170H0238
		160		PV-160A-01XL	SD1XL-S-PV	170H0236/170H0238
2	1000 V d.c.	160	Bladed version	PV-160A-2XL	SD2XL-S-PV	170H0236/170H0238
		200		PV-200A-2XL	SD2XL-S-PV	170H0236/170H0238
		250		PV-250A-2XL	SD2XL-S-PV	170H0236/170H0238
		315		PV-315A-2XL	SD2XL-S-PV	170H0236/170H0238
		355		PV-355A-2XL	SD2XL-S-PV	170H0236/170H0238
3	1000 V d.c.	350		PV-350A-3L	SD3L-S-PV	170H0236/170H0238
		400		PV-400A-3L	SD3L-S-PV	170H0236/170H0238
		500		PV-500A-3L	SD3L-S-PV	170H0236/170H0238
		600		PV-600A-3L	SD3L-S-PV	170H0236/170H0238
01	1000 V d.c.	63		PV-63A-01XL-B		170H0069
		80		PV-80A-01XL-B		170H0069
		100		PV-100A-01XL-B		170H0069
		125		PV-125A-01XL-B		170H0069
		160		PV-160A-01XL-B		170H0069
2	1000 V d.c.	160	Bolted version	PV-160A-2XL-B		170H0069
		200		PV-200A-2XL-B		170H0069
		250		PV-250A-2XL-B		170H0069
		315		PV-315A-2XL-B		170H0069
		355		PV-355A-2XL-B		170H0069
		160		PV-160A-2XL-3B <sup>1</sup>		170H0069
		200		PV-200A-2XL-3B <sup>1</sup>		170H0069
		250		PV-250A-2XL-3B <sup>1</sup>		170H0069
		315		PV-315A-2XL-3B <sup>1</sup>		170H0069
		355		PV-355A-2XL-3B <sup>1</sup>		170H0069
3	1000 V d.c.	350		PV-350A-3L-B	170H0069	
		400		PV-400A-3L-B	170H0069	
		500		PV-500A-3L-B	170H0069	
		600		PV-600A-3L-B	170H0069	

# PV-XL, XL Style photovoltaic fuse links, 50 to 600 A, 1000/1500 V d.c.

## Compatible fuse bases and microswitches - 1500 V d.c.- Bladed

Fuse link body size	Rated voltage	Rated current (Amps)	Fuse type	Catalogue numbers	Compatible XL Bases	Compatible micro-switches
01	1500 V d.c.	50		PV-50A-01XL-15	SD1XL-S-PV	170H0236/170H0238
		63		PV-63A-01XL-15	SD1XL-S-PV	170H0236/170H0238
		80		PV-80A-01XL-15	SD1XL-S-PV	170H0236/170H0238
		100		PV-100A-01XL-15	SD1XL-S-PV	170H0236/170H0238
		125		PV-125A-01XL-15	SD1XL-S-PV	170H0236/170H0238
1	1500 V d.c.	100		PV-100A-1XL-15	SD1XL-S-PV	170H0236/170H0238
		125		PV-125A-1XL-15	SD1XL-S-PV	170H0236/170H0238
		160		PV-160A-1XL-15	SD1XL-S-PV	170H0236/170H0238
		200		PV-200A-1XL-15	SD1XL-S-PV	170H0236/170H0238
		125		PV-125A-2XL-15	SD2XL-S-PV	170H0236/170H0238
2	1500 V d.c.	160	Bladed with top indicator	PV-160A-2XL-15	SD2XL-S-PV	170H0236/170H0238
		200		PV-200A-2XL-15	SD2XL-S-PV	170H0236/170H0238
		250		PV-250A-2XL-15	SD2XL-S-PV	170H0236/170H0238
		250		PV-250A-3L-15	SD3L-S-PV	170H0236/170H0238
3	1500 V d.c.	315		PV-315A-3L-15	SD3L-S-PV	170H0236/170H0238
		350		PV-350A-3L-15	SD3L-S-PV	170H0236/170H0238
		355		PV-355A-3L-15	SD3L-S-PV	170H0236/170H0238
		400		PV-400A-3L-15	SD3L-S-PV	170H0236/170H0238
		450		PV-450A-3L-15	SD3L-S-PV	170H0236/170H0238
2	1500 V d.c.	500		PV-500A-3L-15	SD3L-S-PV	170H0236/170H0238
		125		PV-125A-2XL-U-15	SD2XL-S-PV	
		160		PV-160A-2XL-U-15	SD2XL-S-PV	
		200		PV-200A-2XL-U-15	SD2XL-S-PV	
		250		PV-250A-2XL-U-15	SD2XL-S-PV	
3	1500 V d.c.	250	Bladed without top indicator	PV-250A-3L-U-15	SD3L-S-PV	
		315		PV-315A-3L-U-15	SD3L-S-PV	
		350		PV-350A-3L-U-15	SD3L-S-PV	
		355		PV-355A-3L-U-15	SD3L-S-PV	
		400		PV-400A-3L-U-15	SD3L-S-PV	
	1500 V d.c.	450		PV-450A-3L-U-15	SD3L-S-PV	
		500		PV-500A-3L-U-15	SD3L-S-PV	

# PV-XL, XL Style photovoltaic fuse links, 50 to 600 A, 1000/1500 V d.c.

## Compatible fuse bases and microswitches - 1500 V d.c.- Bolted

Fuse link body size	Rated voltage	Rated current (Amps)	Fuse type	Catalogue number	Compatible XL Bases	Compatible micro-switches	
01	1500 V d.c.	50		PV-50A-01XL-B-15		170H0069	
		63		PV-63A-01XL-B-15		170H0069	
		80		PV-80A-01XL-B-15		170H0069	
		100		PV-100A-01XL-B-15		170H0069	
		125		PV-125A-01XL-B-15		170H0069	
1	1500 V d.c.	100		PV-100A-1XL-B-15		170H0069	
		125		PV-125A-1XL-B-15		170H0069	
		160		PV-160A-1XL-B-15		170H0069	
		200		PV-200A-1XL-B-15		170H0069	
		125		PV-125A-2XL-B-15		170H0069	
2	1500 V d.c.	160	Bolted version with side indicator	PV-160A-2XL-B-15		170H0069	
		200		PV-200A-2XL-B-15		170H0069	
		250		PV-250A-2XL-B-15		170H0069	
		125		PV-125A-2XL-3B-15		170H0069	
		160		PV-160A-2XL-3B-15		170H0069	
		200		PV-200A-2XL-3B-15		170H0069	
		250		PV-250A-2XL-3B-15		170H0069	
		250		PV-250A-3L-B-15		170H0069	
		315		PV-315A-3L-B-15		170H0069	
		350		PV-350A-3L-B-15		170H0069	
3	1500 V d.c.	355		PV-355A-3L-B-15		170H0069	
		400		PV-400A-3L-B-15		170H0069	
		450		PV-450A-3L-B-15		170H0069	
		500		PV-500A-3L-B-15		170H0069	
		125		PV-125A-2XL-BU-15			
		160		PV-160A-2XL-BU-15			
200	PV-200A-2XL-BU-15						
250	PV-250A-2XL-BU-15						
125	PV-125A-2XL-3BU-15						
160	PV-160A-2XL-3BU-15						
200	PV-200A-2XL-3BU-15						
250	PV-250A-2XL-3BU-15						
2	1500 V d.c.	250	Bolted without side indicator	PV-250A-3L-BU-15			
		315		PV-315A-3L-BU-15			
		350		PV-350A-3L-BU-15			
		355		PV-355A-3L-BU-15			
		400		PV-400A-3L-BU-15			
		450		PV-450A-3L-BU-15			
3	1500 V d.c.	500		PV-500A-3L-BU-15			

# PV-XL, XL Style photovoltaic fuse links, 50 to 600 A, 1000/1500 V d.c.

## Dimensions (mm)- size 01 Bladed

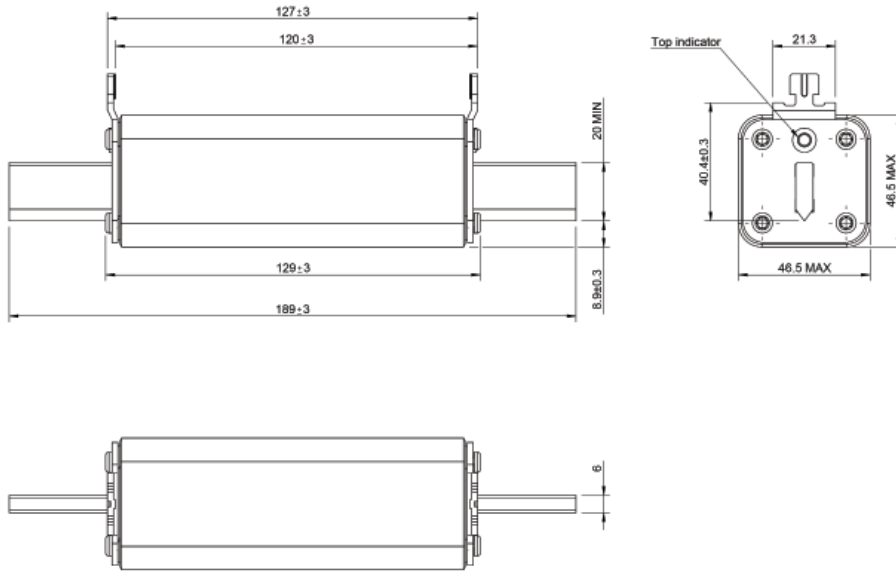

## Dimensions (mm) - size 1 Bladed

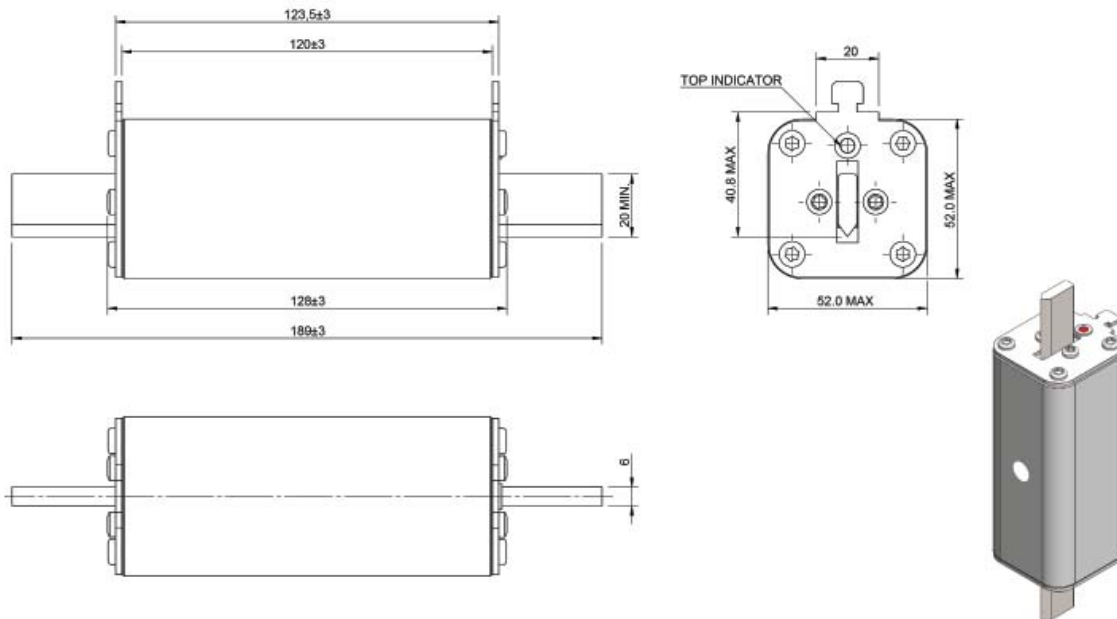

# PV-XL, XL Style photovoltaic fuse links, 50 to 600 A, 1000/1500 V d.c.

## Dimensions (mm) - size 2 Bladed

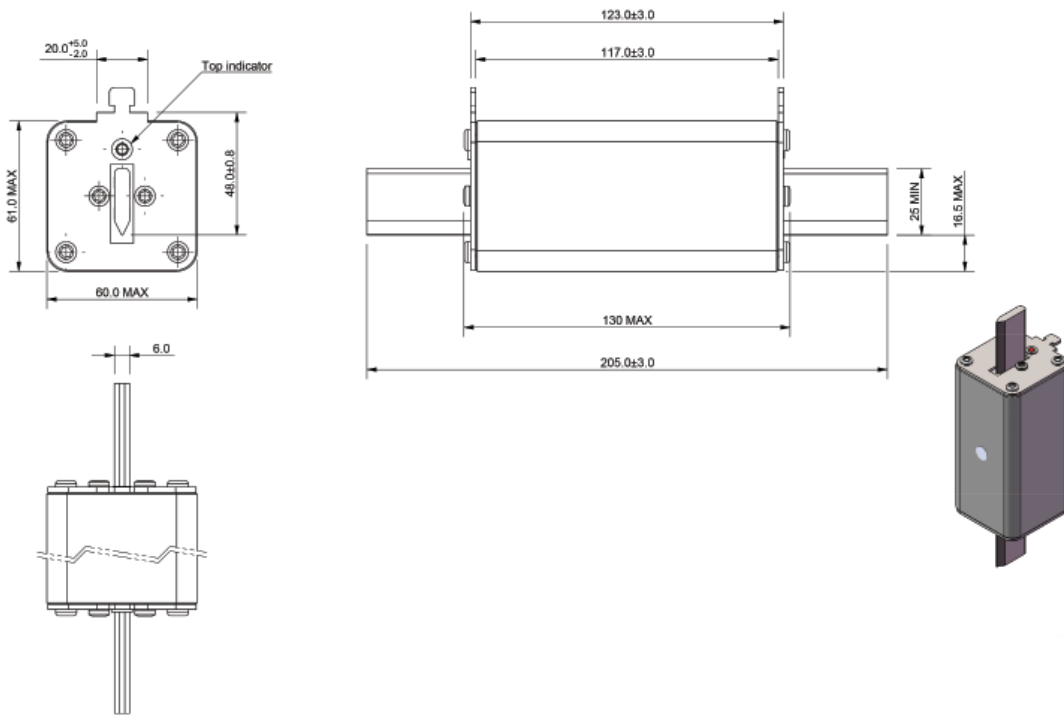

## Dimensions (mm) - size 3 Bladed

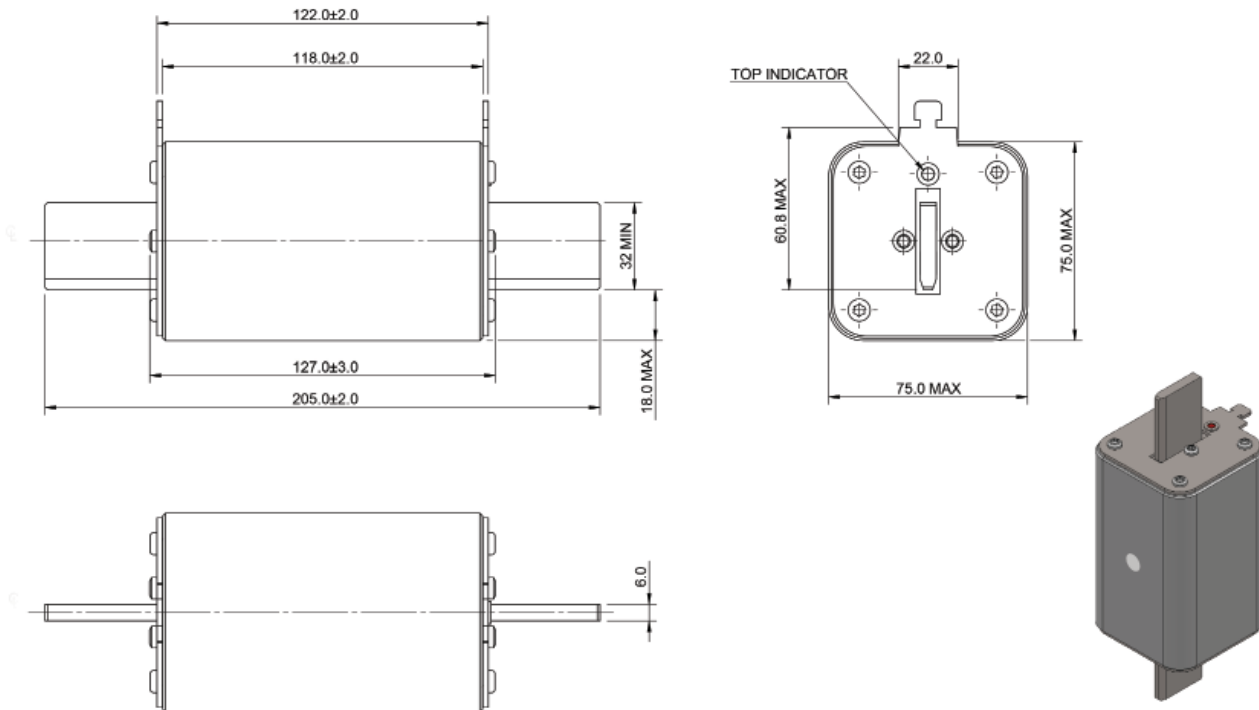

# PV-XL, XL Style photovoltaic fuse links, 50 to 600 A, 1000/1500 V d.c.

## Dimensions (mm) - size 01 Bolted

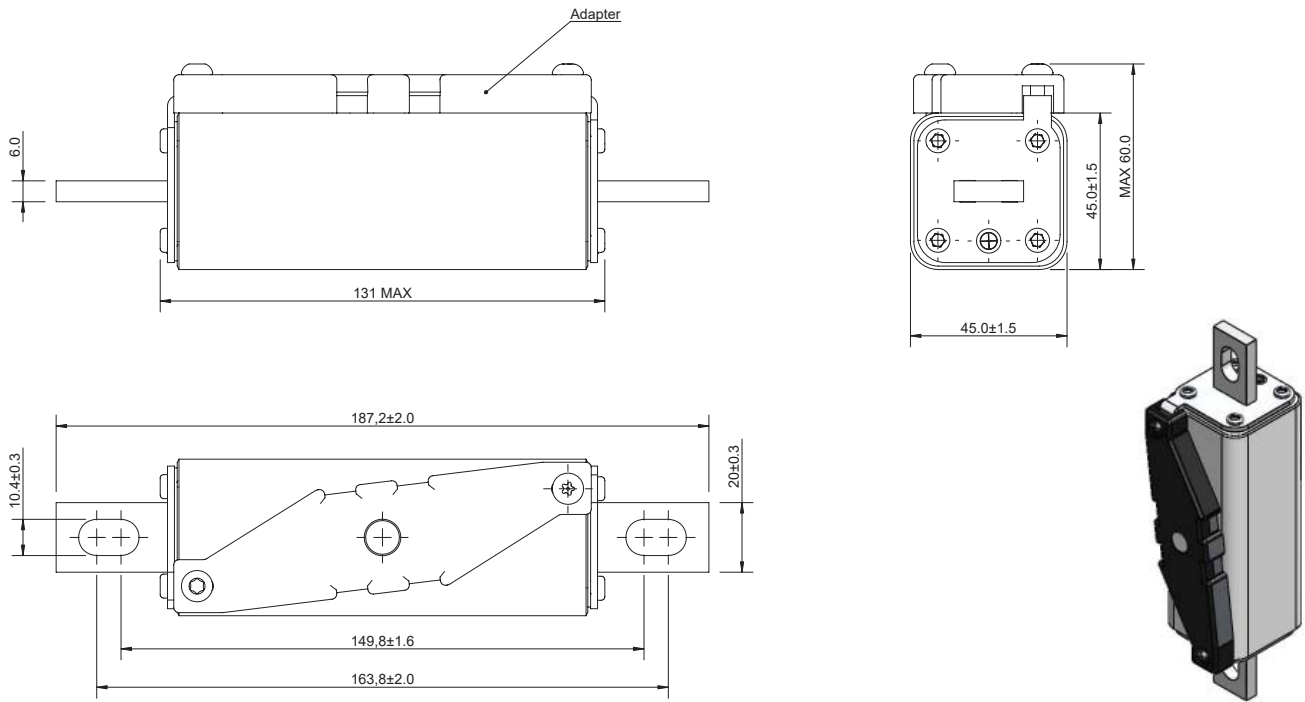

## Dimensions (mm) - size 1 Bolted

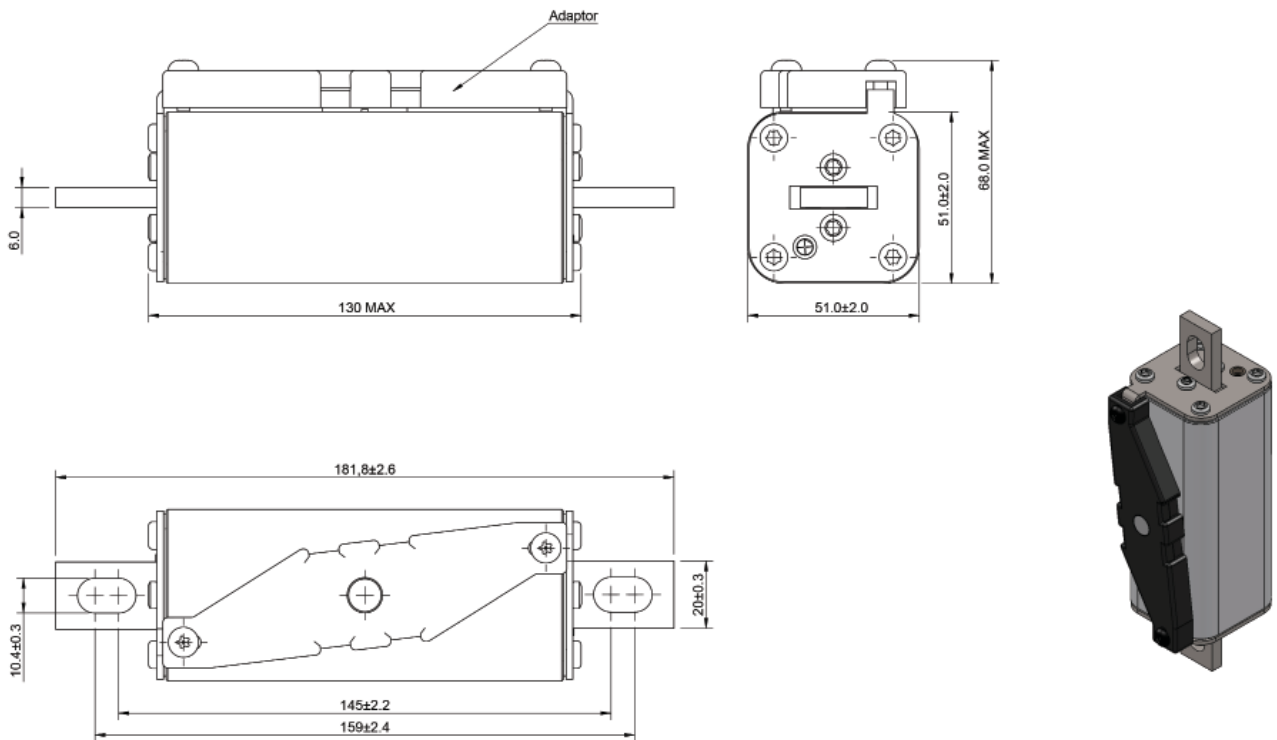
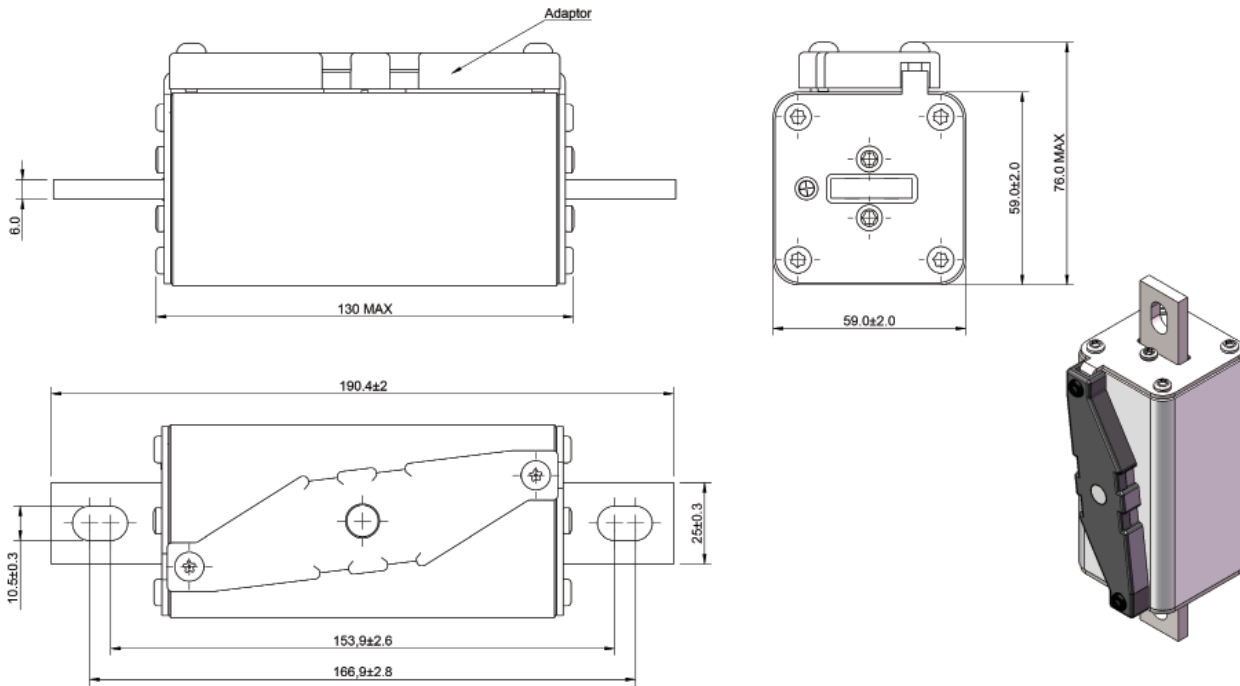

FIG. 4 FUSE XL PV BOLTED

# PV-XL, XL Style photovoltaic fuse links, 50 to 600 A, 1000/1500 V d.c.

## Dimensions (mm) - size 2 Bolted



## Dimensions (mm) - size 2XL-3B Bolted

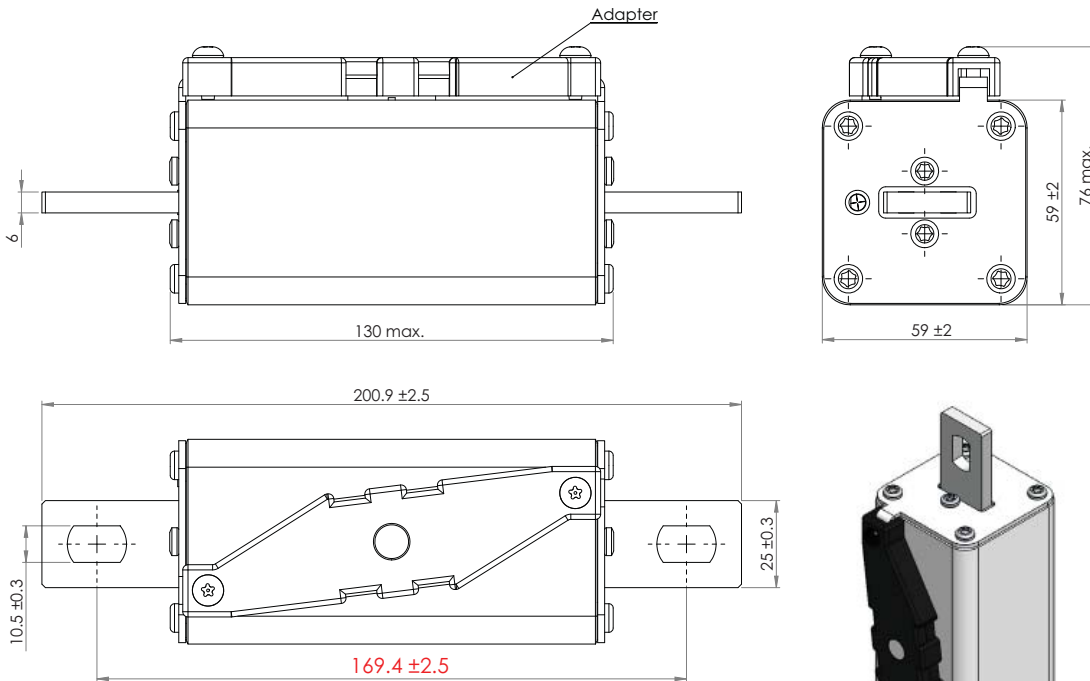

PV-\*A-2XL-3B and PV-\*A-2XL-3B-15 have revised bolting patterns, which are identical to size 3L bolting pattern. This allows utilisation of both size 2XL and size 3L fuse links without changing the dimensional layout of the inverter, combiners and disconnects.

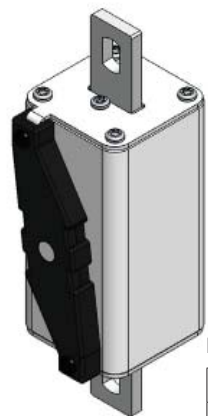

Mounting dimensions comparison

2XL-3B	3L
169.4	170.8

# PV-XL, XL Style photovoltaic fuse links, 50 to 600 A, 1000/1500 V d.c.

## Dimensions (mm) - size 3 Bolted

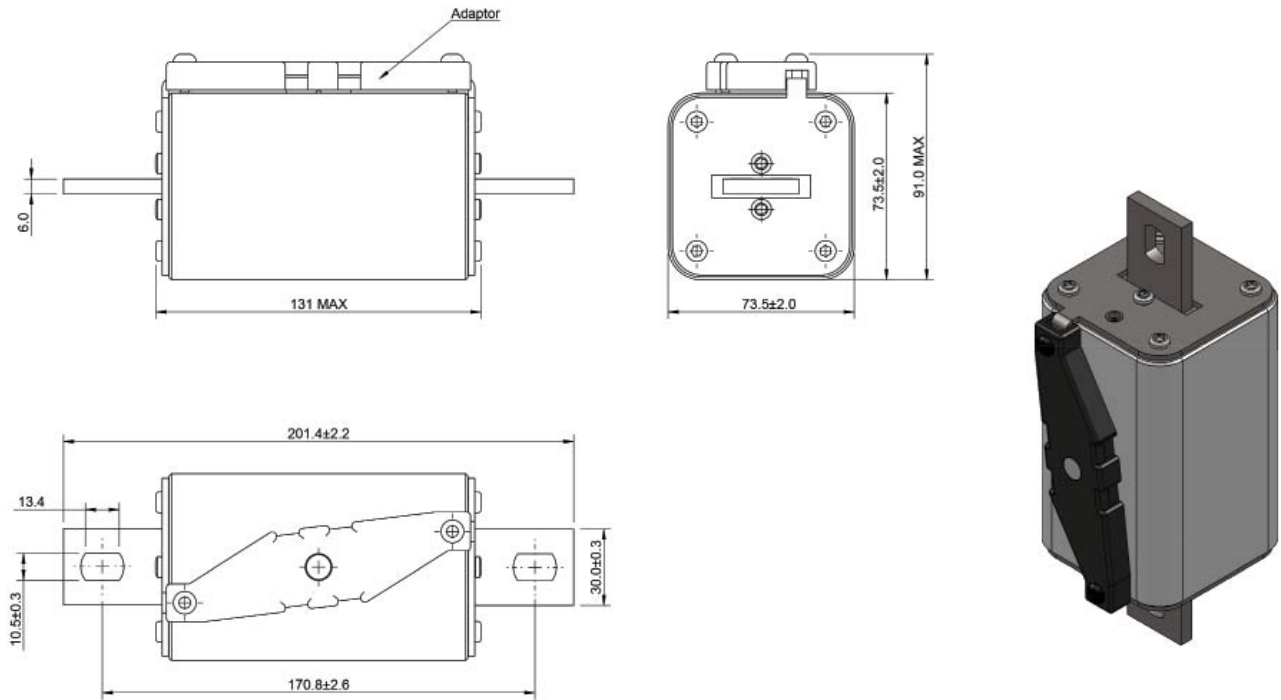

## Time-current curve - 1000 V d.c. - 01XL - Bladed and bolted - 63 A to 160 A

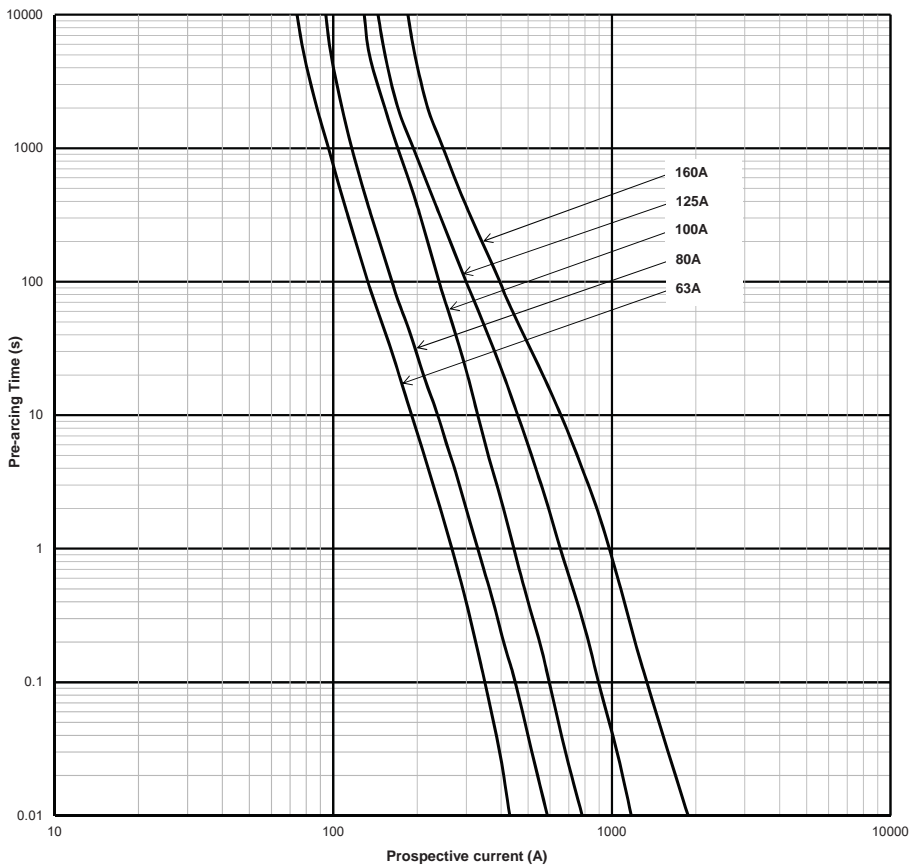

# PV-XL, XL Style photovoltaic fuse links, 50 to 600 A, 1000/1500 V d.c.

Time-current curve - 1000 V d.c. - 2XL - Bladed and bolted - 160 A to 355 A

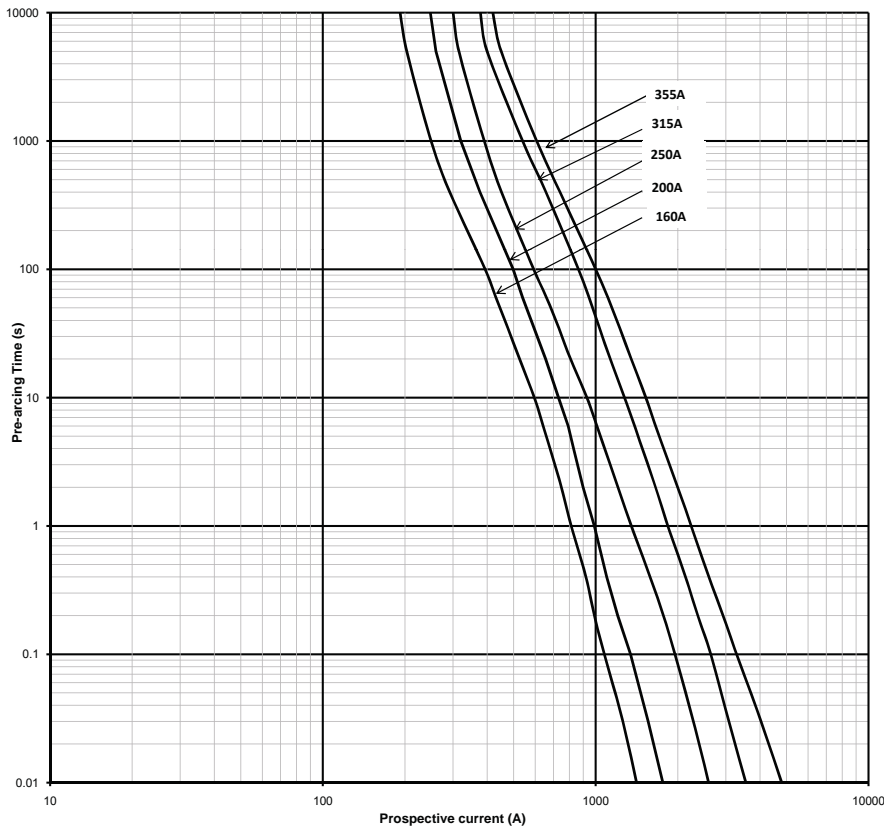

Time-current curve - 1000 V d.c. - 3L - Bladed and bolted - 350 A to 600 A

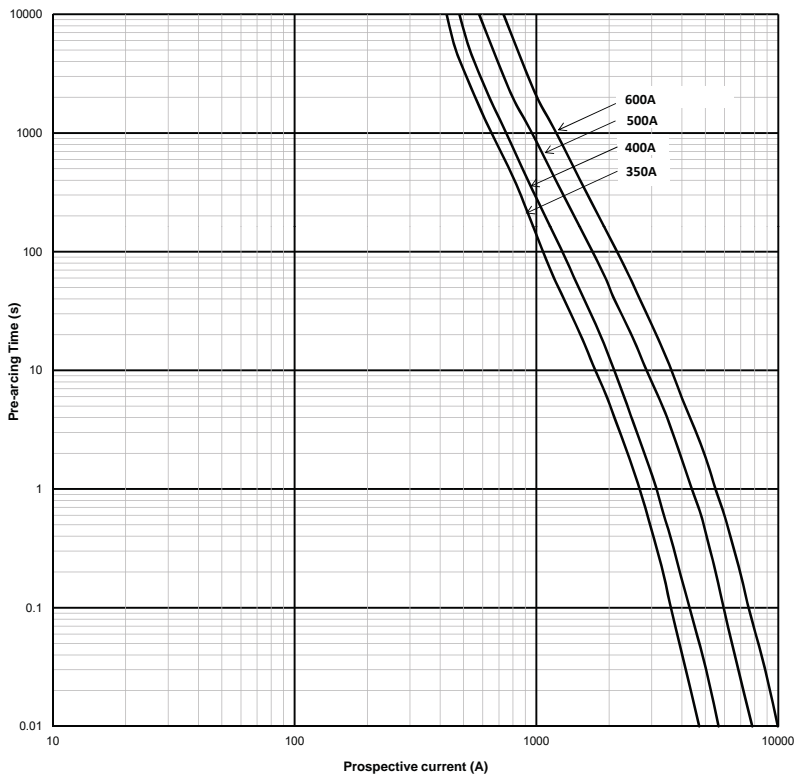

# PV-XL, XL Style photovoltaic fuse links, 50 to 600 A, 1000/1500 V d.c.

**Time-current curve - 1500 V d.c. - 01XL - Bladed and bolted - 50 A to 125 A**

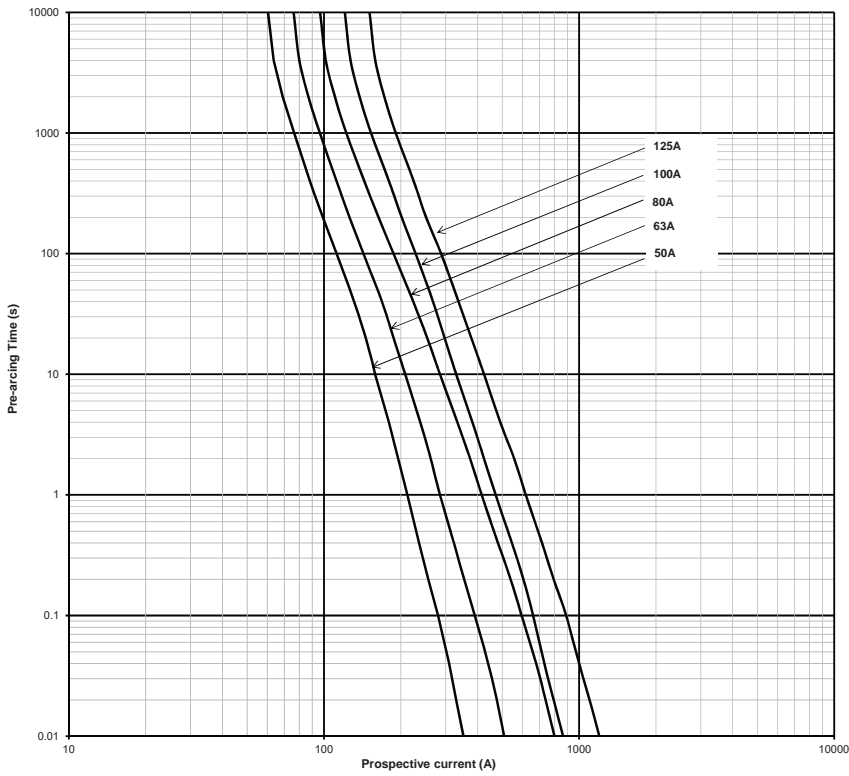

**Time-current curve - 1500 V d.c. - 1XL - Bladed and bolted - 100 A to 200 A**

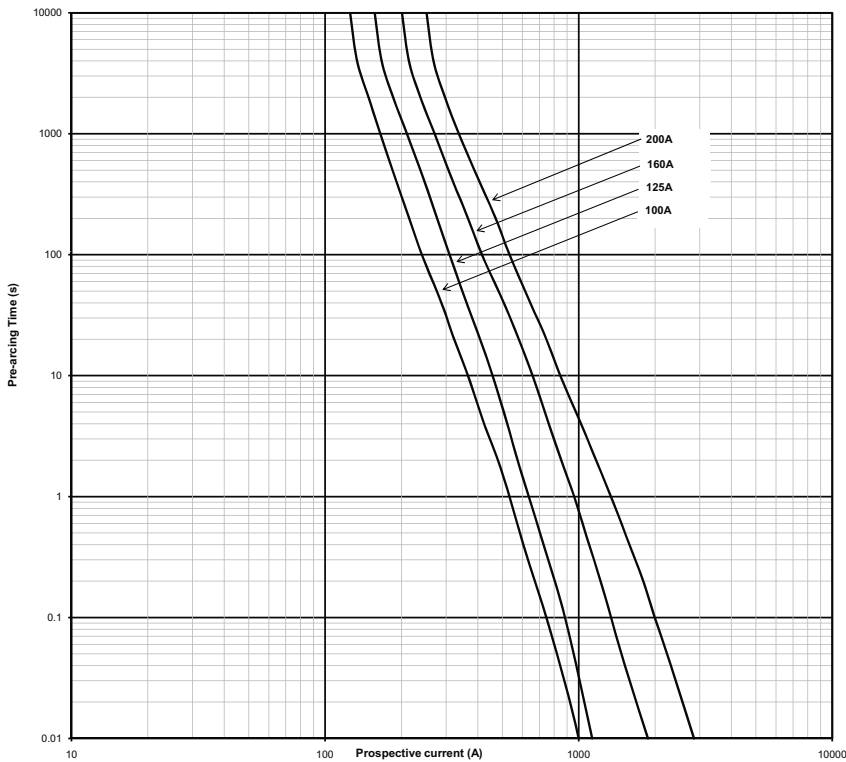

# PV-XL, XL Style photovoltaic fuse links, 50 to 600 A, 1000/1500 V d.c.

Time-current curve - 1500 V d.c. - 2XL - Bladed and bolted - 125 A to 250 A

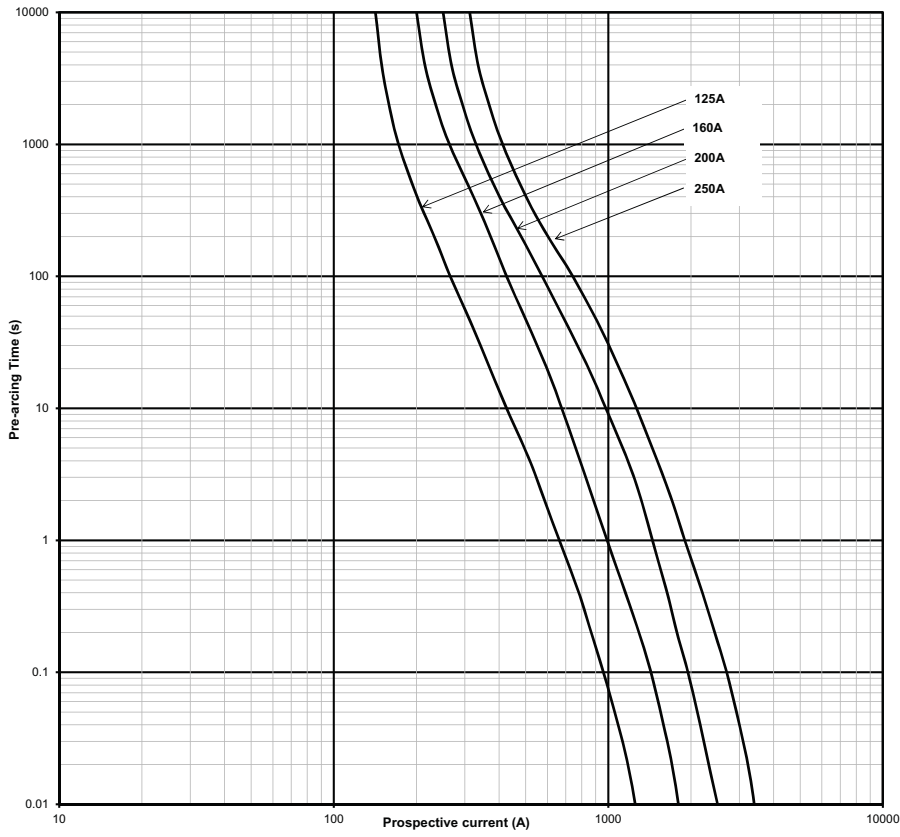

Time-current curve - 1500 V d.c. - 3L - Bladed and bolted - 250 A to 500 A

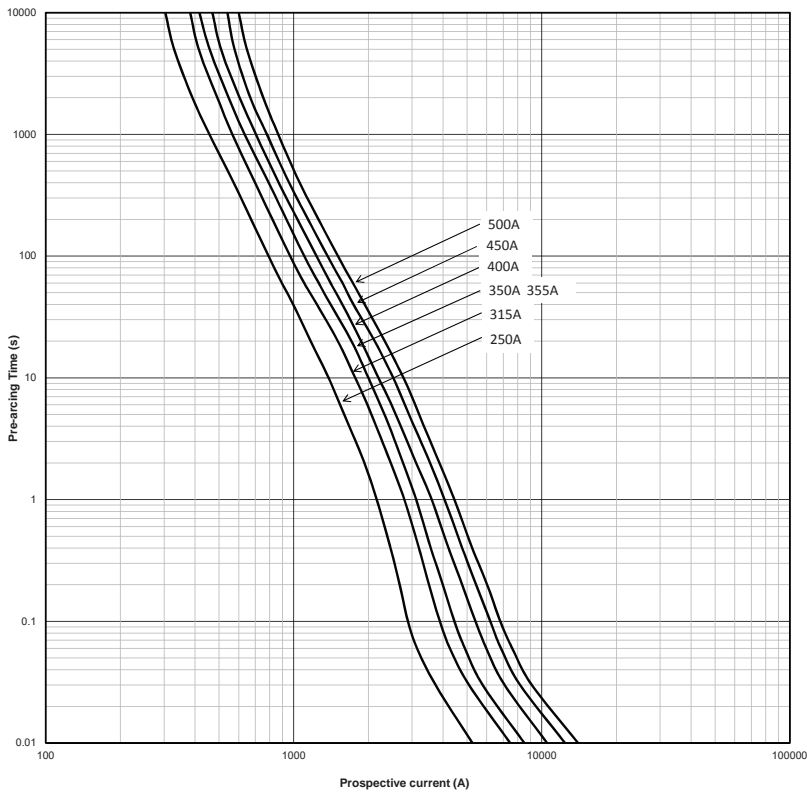

# PV-XL, XL Style photovoltaic fuse links, 50 to 600 A, 1000/1500 V d.c.

Temperature derating curve

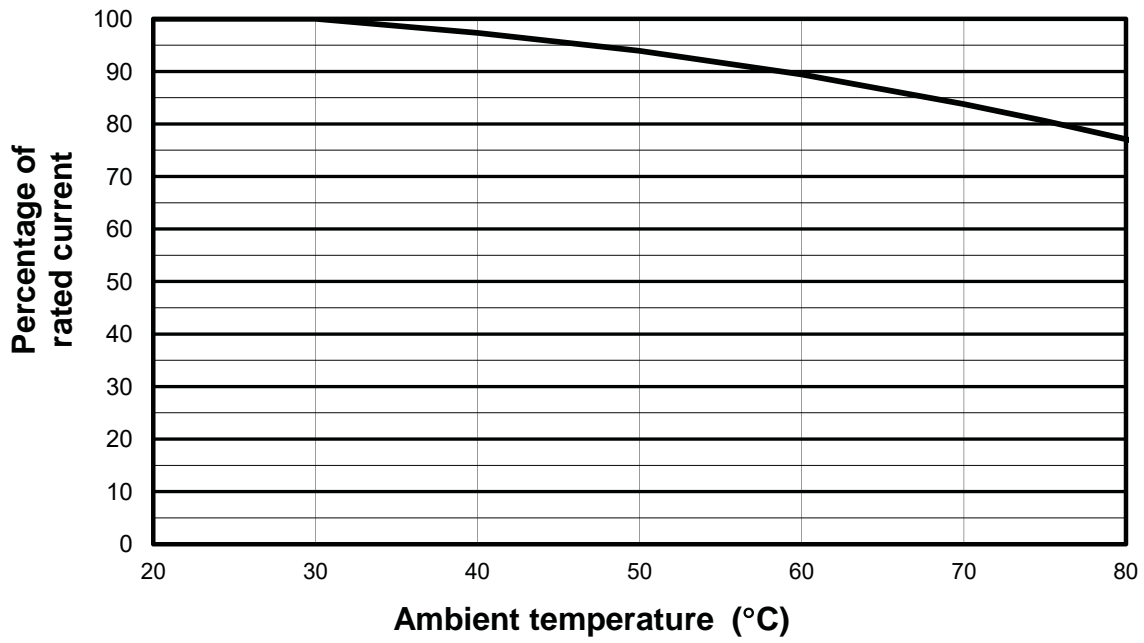

# SD-S-PV, XL bases for XL style PV fuse links, 200 to 500 A, 1500 V d.c.

## Description

Sizes 1 to 3 XL Fuse bases specifically designed for use with the Bussmann series range of XL PV (Photovoltaic) fuse links.

## Technical data

Rated voltage: 1500 V d.c. (IEC)

Rated current: 200, 400 and 630 A

Fuse base size: 1 to 3

## Standards / Agency information

IEC 60269-1

UL Listed (file number E348242)

## Accessories:

Fuse extraction handle available in sizes 01XL to 3L

Part numbers: FEH1500B

Unit packing: 1

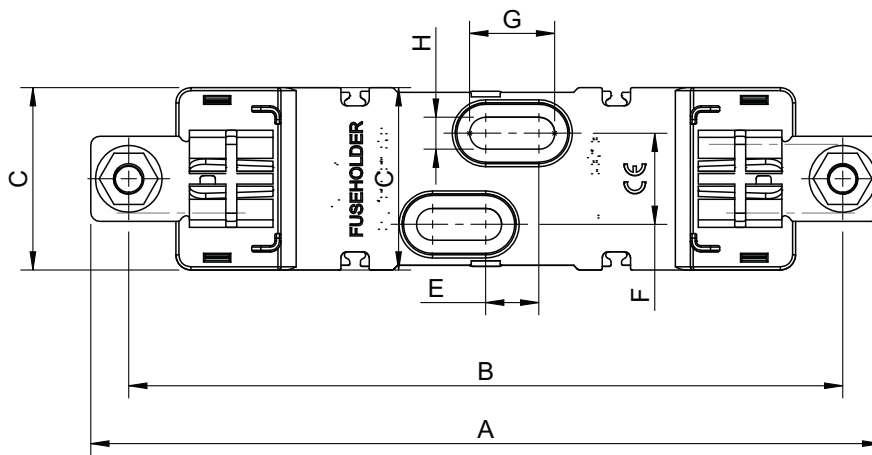
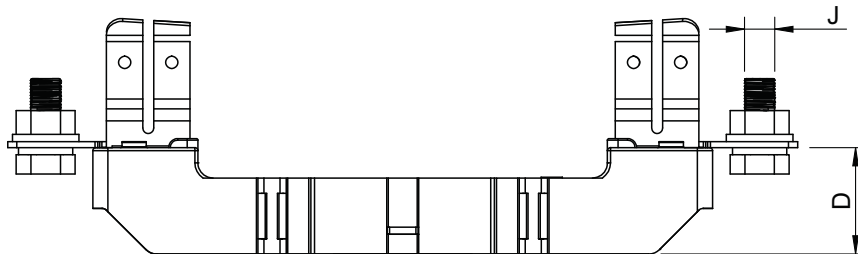

Catalogue numbers	XL Style fuse link size	Maximum fuse rated current (Amps)	Power acceptance	A	B	C	D	E	F	G	H	J
SD1XL-S-PV	01XL, 1XL	200	57W	260	235	60	35	17.5	30	28	10.5	M10
SD2XL-S-PV	2XL	400	75W	285	260	60	35	17.5	30	28	10.5	M12
SD3L-S-PV	3L	500	108W	300	270	60	35	17.5	30	28	10.5	M12

# 170M, NH Photovoltaic fuse links, 32 A to 400 A, 800 V a.c.

## Description

Eaton's Bussmann series NH size 800 V a.c. fuse links are specifically designed to meet the needs of branch circuit and transformer protection in photovoltaic inverter systems. The fuse links are capable of interrupting low overcurrents associated with faulted PV systems (reverse current, multi-array fault).

## Technical data

Rated voltage: 800 V a.c.

Rated current: 32 A to 400 A

Breaking capacity: 65 kA

Operating class: gR

## Standards / Agency information

UL 248-13 (file number E125085)

IEC 60269-4 (see details below)



## Catalogue numbers - Bladed with lugs

Fuse link body size	Rated voltage	Rated current (Amps)	I <sup>2</sup> t (A <sup>2</sup> Sec)		Watts loss (W)		Catalogue numbers	
			Pre-arcing	Total at 800 V a.c.	I <sub>n</sub>	Bladed with lugs	Compatible fuse base	Compatible microswitches
NH1	800 V a.c.	32	80	2000	8	170M7350	SD-1-D	170H0236 and 170H0238
		40	185	3000	9	170M7351	SD-1-D	170H0236 and 170H0238
		50	400	6000	11	170M7352	SD-1-D	170H0236 and 170H0238
		63	470	7000	12	170M7353*	SD-1-D	170H0236 and 170H0238
		80	640	9000	15	170M7354	SD-1-D	170H0236 and 170H0238
		100	1300	17000	16	170M7355	SD-1-D	170H0236 and 170H0238
		125	2600	34000	17	170M7356*	SD-1-D	170H0236 and 170H0238
		160	5200	68000	27	170M7357*	SD-1-D	170H0236 and 170H0238
NH2	800 V a.c.	200	10200	140000	25	170M7358*	SD-1-D	170H0236 and 170H0238
		160	4600	36800	28	170M7397	SD-2-D	170H0236 and 170H0238
		200	9500	76000	32	170M7398	SD-2-D	170H0236 and 170H0238
NH3	800 V a.c.	250	17000	136000	38	170M7399	SD-2-D	170H0236 and 170H0238
		315	32000	230000	44	170M7400*	SD-3-D	170H0236 and 170H0238
NH3	800 V a.c.	355	44500	320000	46	170M7401*	SD-3-D	170H0236 and 170H0238
		400	67500	480000	50	170M7402*	SD-3-D	170H0236 and 170H0238

## Catalogue numbers - Blade with bolt holes no lugs

Fuse link body size	Rated voltage	Rated current (Amps)	I <sup>2</sup> t (A <sup>2</sup> Sec)		Watts loss (W)		Catalogue numbers	
			Pre-arcing	Total at 800 V a.c.	I <sub>n</sub>	Blade with bolt holes no lugs		
NH1	800 V a.c.	63	470	7000	12	170M7353-B*		
		80	640	9000	15	170M7354-B		
		100	1300	17000	16	170M7355-B		
		125	2600	34000	17	170M7356-B*		
		160	5200	68000	27	170M7357-B*		
		200	10200	140000	25	170M7358-B*		
NH2	800 V a.c.	160	4600	36800	28	170M7397-B		
		200	9500	76000	32	170M7398-B		
NH3	800 V a.c.	250	17000	136000	38	170M7399-B		
		315	32000	230000	44	170M7400-B*		
NH3	800 V a.c.	355	38000	270000	48	170M7401-B*		
		400	61000	430000	50	170M7402-B*		

\*UL 248-13 and IEC 60269-4

Data sheet: 10784

# 170M, NH Photovoltaic fuse links, 32 A to 400 A, 800 V a.c.

## Dimensions (mm), NH1 Bladed with lugs

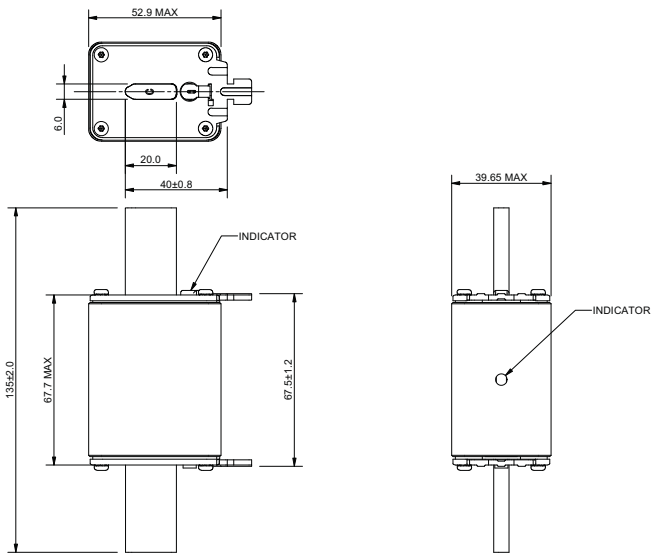

## Dimensions (mm), NH2 Bladed with lugs

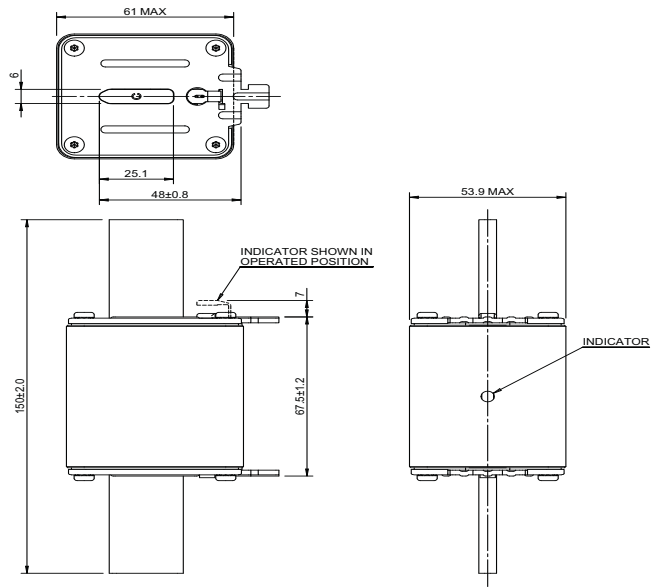

## Dimensions (mm), NH3 Bladed with lugs

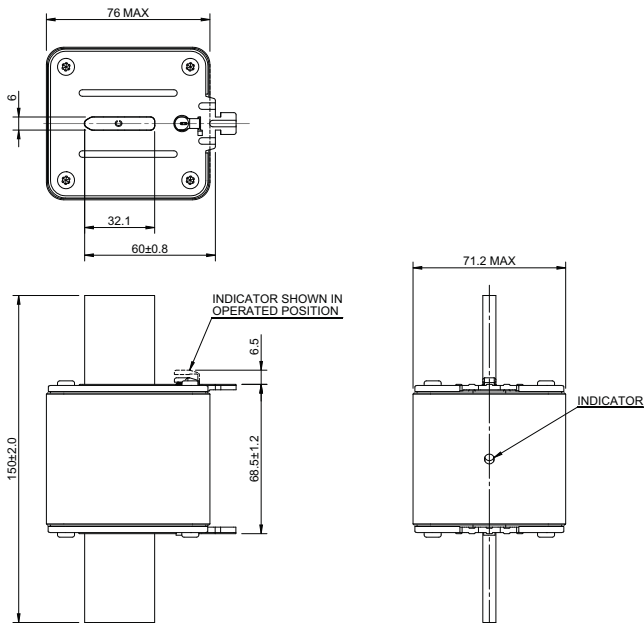

# 170M, NH Photovoltaic fuse links, 32 A to 400 A, 800 V a.c.

Dimensions (mm), NH1 Bolt holes no lugs

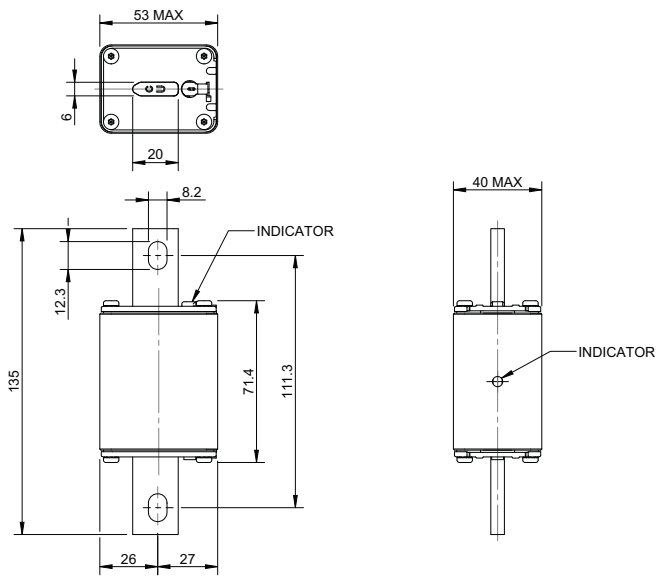

Dimensions (mm), NH2 Bolt holes no lugs

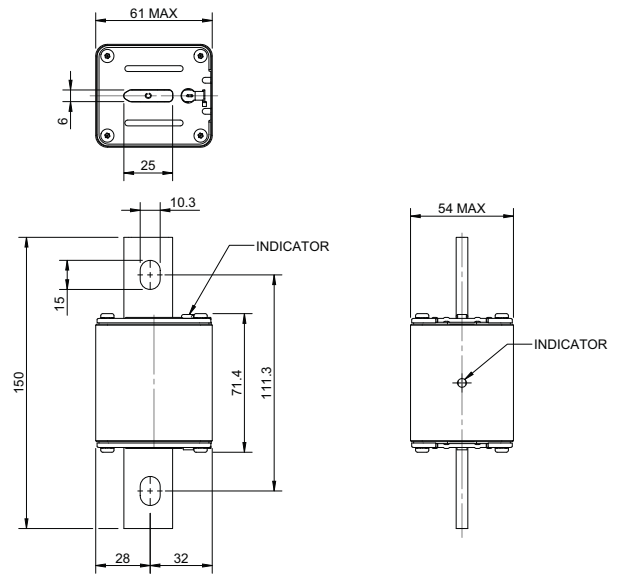

Dimensions (mm), NH3 Bolt holes no lugs

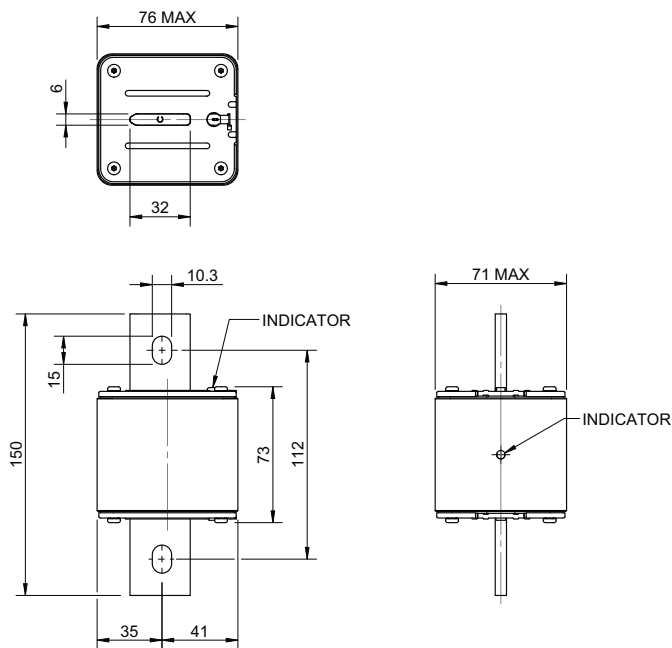

# 170M, NH Photovoltaic fuse links, 32 A to 400 A, 800 V a.c.

## Time-current curve size 1 - 32 A to 200 A

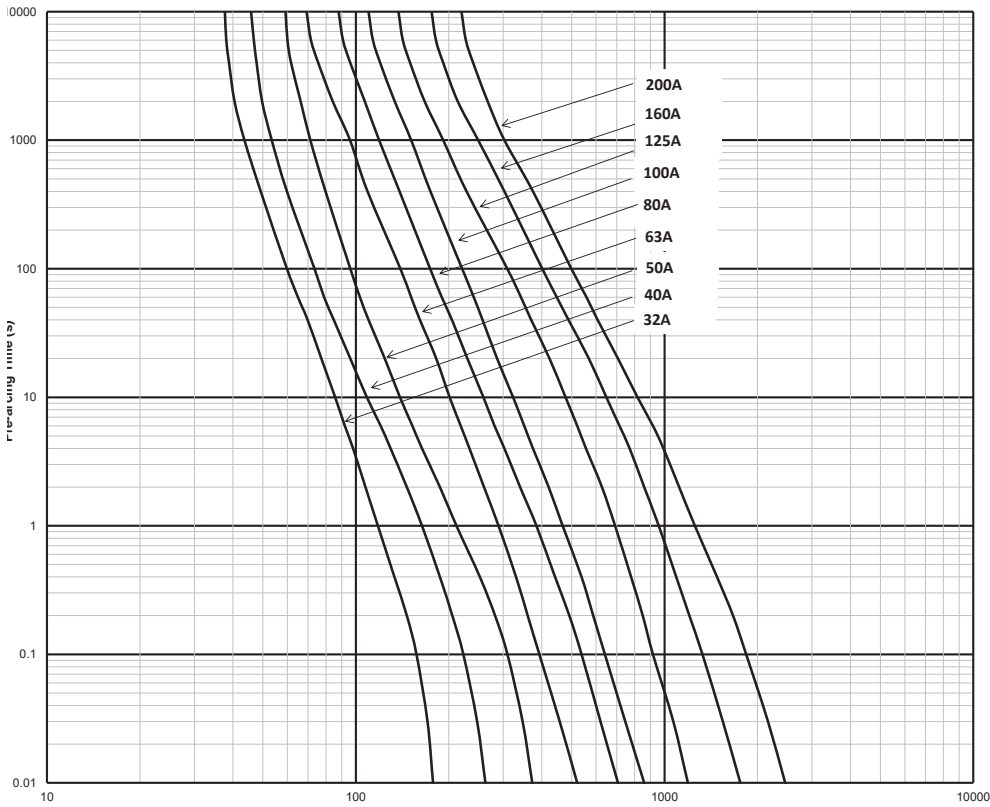

## Time-current curve size 2 - 160 A to 250 A

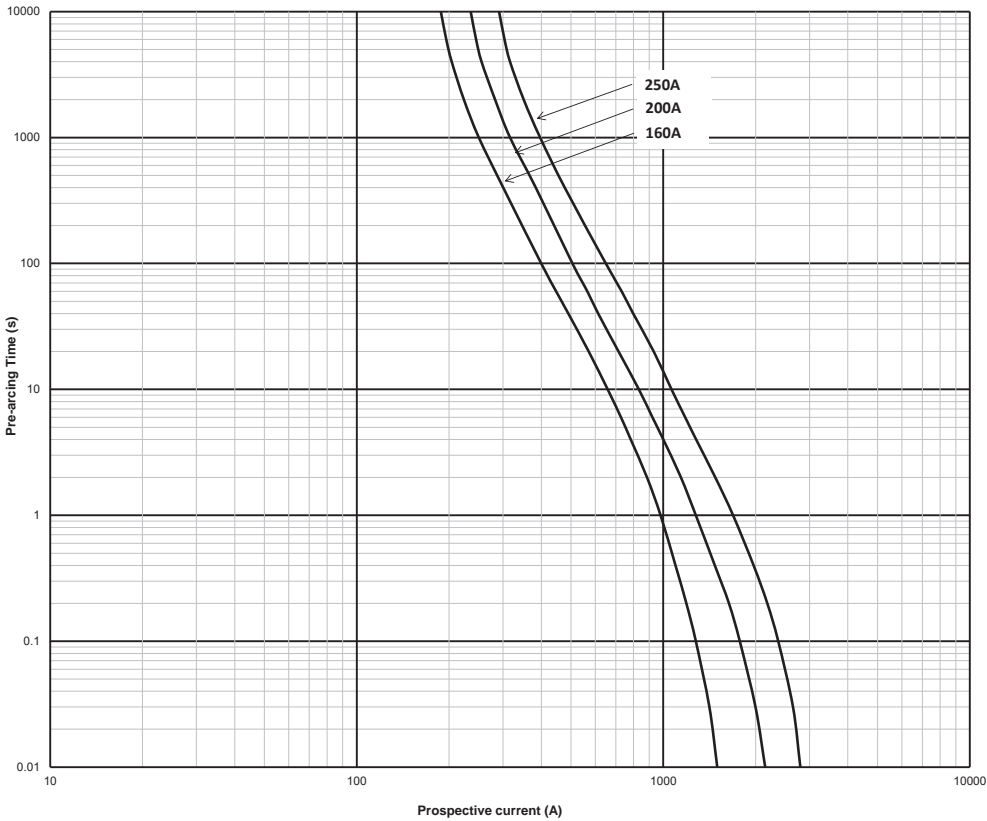

# 170M, NH Photovoltaic fuse links, 32 A to 400 A, 800 V a.c.

## Time-current curve size 3 - 315 A to 400 A

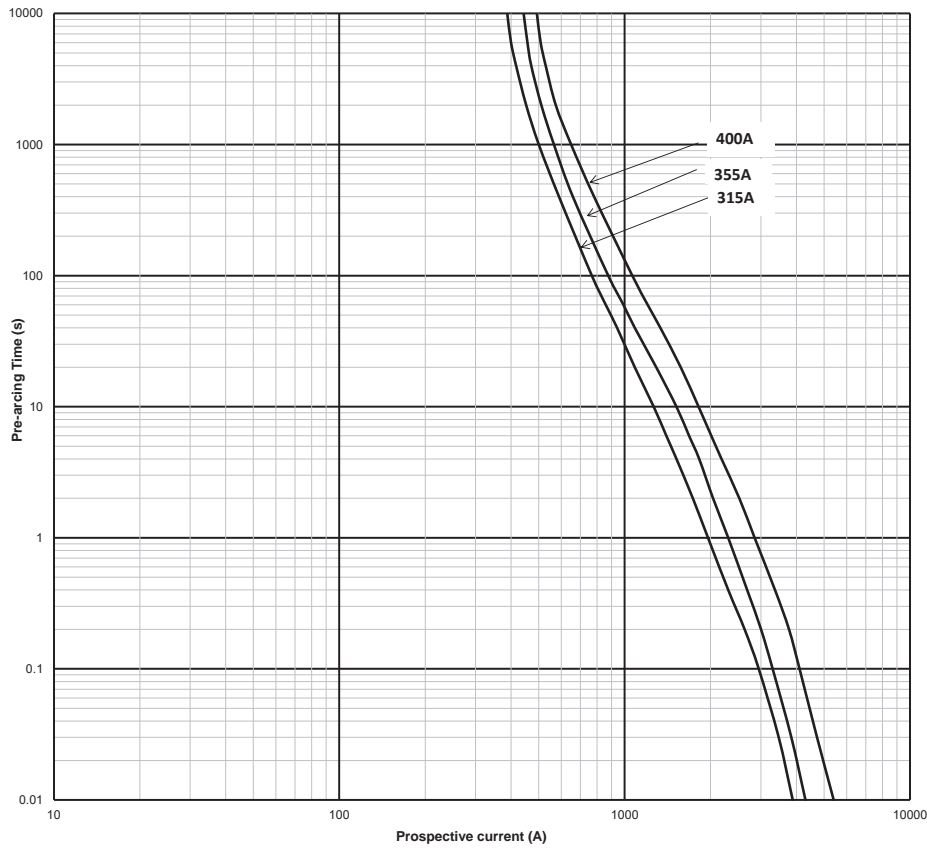

## Temperature derating curve

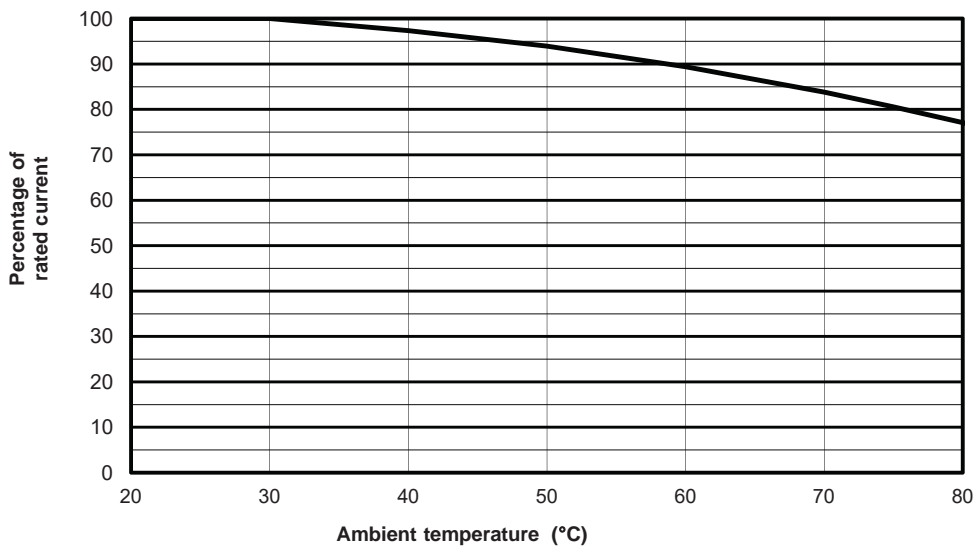

# 170H Microswitches

## Description

Eaton's microswitches are used for remote electrical indication of fuse link operations. All microswitches have one normally open and one normally closed contact.

### 170H0236 and 170H0238 - Type T Indicator

The indicator is situated on one cover plate with a cover plate tag to accommodate an auxiliary switch. The minimum rated voltage for operating the indicator is 20 V. A special low rated voltage indicator (1.5V) is available on request).

### 170H0069 - Type K Indicator

The indicator is situated on the fuse link body. It is covered by an adaptor for snap-on mounting of an auxiliary switch. The operating Rated voltage of the indicator is 1.5V. As a matter of safety, the factory mounted adaptor must not be removed from the fuse link.



## Compatible fuse links

Body size	Fixings/Tags	Catalogue number	Rated voltage	Rated current	Microswitches
<b>NH Fuse links</b>					
1	Bladed with lugs	170M7350 to 170M7358		32 A to 200 A	170H0236 and 170H0238
2	Bladed with lugs	170M7397 to 170M7399	800 V a.c.	160 A to 250 A	170H0236 and 170H0238
3	Bladed with lugs	170M7400 to 170M7402		315 A to 400 A	170H0236 and 170H0238
1	Blade without bolt holes	PV-(amps)ANH1			
	Blade with bolt holes	PV-(amps)ANH1-B	1000 V d.c.	32 A to 200 A	170H0236 and 170H238
	Blade with bolt holes and lugs	PV-(amps)ANH1-BL			
2	Blade without bolt holes	PV-(amps)ANH2			
	Blade with bolt holes	PV-(amps)ANH2-B	1000 V d.c.	160 A to 250 A	170H0236 and 170H238
	Blade with bolt holes and lugs	PV-(amps)ANH2-BL			
3	Blade without bolt holes	PV-(amps)ANH3			
	Blade with bolt holes	PV-(amps)ANH3-B	1000 V d.c.	300 A to 400 A	170H0236 and 170H238
	Blade with bolt holes and lugs	PV-(amps)ANH3-BL			
<b>XL Fuse links</b>					
01XL	Bladed	PV-(amps)A-01XL	1000 V d.c.	63 A to 160 A	170H0236 and 170H0238
	Bolted	PV-(amps)A-01XL-B			170H0069
2	Bladed	PV-(amps)A-2XL			170H0236 and 170H0238
	Bolted	PV-(amps)A-2XL-B	1000 V d.c.	160 A to 355 A	170H0069
		PV-(amps)A-2XL-3B			
3	Bladed	PV-(amps)A-3L	1000 V d.c.	350 A to 600 A	170H0236 and 170H0238
	Bolted	PV-(amps)A-3L-B			170H0069
01	Bladed with top indicator	PV-(amps)A-01XL-15	1500 V d.c.	50 A to 125 A	170H0236 and 170H0238
	Bolted with side indicator	PV-(amps)A-01XL-B-15			170H0069
1	Bladed with top indicator	PV-(amps)A-1XL-15	1500 V d.c.	100 A to 200 A	170H0236 and 170H0238
	Bolted with side indicator	PV-(amps)A-1XL-B-15			170H0069
2	Bladed with top indicator	PV-(amps)A-2XL-15			170H0236 and 170H0238
	Bolted with side indicator	PV-(amps)A-2XL-B-15	1500 V d.c.	125 A to 250 A	170H0069
		PV-(amps)A-2XL-3B-15			
3	Bladed with top indicator	PV-(amps)A-3L-15	1500 V d.c.	250 A to 500 A	170H0236 and 170H0238
	Bolted with side indicator	PV-(amps)A-3L-B-15			170H0069

# 170H Microswitches

## Dimensions (mm) - 170H0069

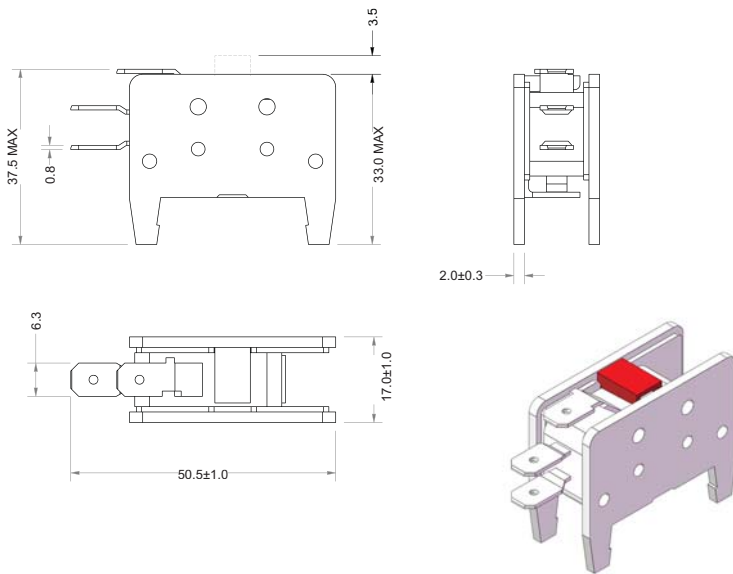

## Dimensions (mm) - 170H0236 and 170H0238 for straight tags

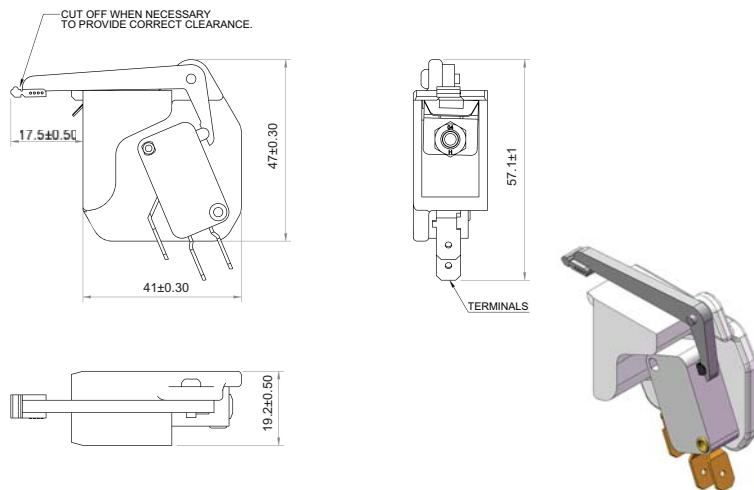

# Index

Catalogue numbers	Pages
170H0069	68
170H0236	68
170H0238	68
170M	63
CHPV	22
CHPV14	28
CHPV15L85	25
FW14-PCB	29
PV-3L	48
PV-A10-1P	17
PV-A10-2P	17
PV-A10-2PS	17
PV-A10F	17
PV-A10F85L	23
PV-A10F-CT	17
PV-A10-T	17
PV-A14F	26
PV-A14LF	30
PV-A14LF10F	30
PV-A14L-T	30
PV-AF	45
PV-ANH	34
PVM	15
PV-XL	48
SD-D-PV	43
SD-S-PV	62

# Contact details

## Customer Satisfaction team

Eaton's Customer Satisfaction team is available to answer questions regarding Bussmann series products.

Calls can be made between:

Monday - Friday: 7.30 a.m. - 5.00 p.m. GMT

The Customer Satisfaction team can be reached via:

Phone: 00 44 (0) 1509 882 600

Fax: 00 44 (0) 1509 882 786

Email: [GBBURsales@eaton.com](mailto:GBBURsales@eaton.com)

## Application engineering

Application Engineering assistance is available to all customers. The Application Engineering team is staffed by university-qualified electrical engineers who are available with technical and application support.

Calls can be made between:

Monday - Thursday: 8.30 a.m. - 4.30 p.m. GMT

Friday: 8.30 a.m. - 4.00 p.m. GMT

Application Engineering can be reached via:

Phone: 00 44 (0) 1509 882 699

Fax: 00 44 (0) 1509 882 794

General technical enquiries:

[buletechnical@eaton.com](mailto:buletechnical@eaton.com)

Enquiries related to High speed fuses:

[bulehighspeedtechnical@eaton.com](mailto:bulehighspeedtechnical@eaton.com)

Eaton's mission is to improve the quality of life and the environment through the use of power management technologies and services. We provide sustainable solutions that help our customers effectively manage electrical, hydraulic, and mechanical power – more safely, more efficiently, and more reliably. Eaton's 2020 revenues were \$17.9 billion, and we sell products to customers in more than 175 countries. We have approximately 92,000 employees.

For more information, visit [Eaton.com](http://Eaton.com).

## Contact your local Eaton office

Eaton Electrical Products Limited  
Unit 1, Hawker Business Park  
Melton Road  
Burton-on-the-Wolds  
LE12 5TH  
Leicestershire  
United Kingdom  
[GBBURsales@eaton.com](mailto:GBBURsales@eaton.com)  
[www.eaton.com](http://www.eaton.com)

**Eaton Industries Manufacturing GmbH**  
Electrical Sector EMEA  
Route de la Longeraie  
71110 Morges, Switzerland  
[Eaton.eu](http://Eaton.eu)

© 2021 Eaton  
All Rights Reserved  
PDF only  
Publication number: CA135004EN  
March 2021

Changes to the products, to the information contained in this document, and to prices are reserved; so are errors and omissions. Only order confirmations and technical documentation by Eaton is binding. Photos and pictures also do not warrant a specific layout or functionality. Their use in whatever form is subject to prior approval by Eaton. The same applies to Trademarks (especially Eaton, Moeller, and Cutler-Hammer). The Terms and Conditions of Eaton apply, as referenced on Eaton Internet pages and Eaton order confirmations.

Eaton is a registered trademark.

All other trademarks are property of their respective owners.

Follow us on social media to get the latest product and support information.

